



4800 Ashford Dunwoody Road  
Dunwoody, Georgia 30338  
dunwoodyga.gov | 678.382.6700

## **MEMORANDUM**

**To:** Mayor and City Council

**From:** Michael Smith, Public Works Director

**Date:** February 25, 2019

**Subject:** **Approval of a Contract for Traffic Signal Installation at the new Austin Elementary School**

---

### **ITEM DESCRIPTION**

Approval of a construction contract with R.J. Haynie & Associates, Inc. in the amount of \$171,660 for a new traffic signal installation on Roberts Drive at the new Austin Elementary School.

### **BACKGROUND**

As part of the road improvements for the new Austin Elementary School the city is installing a new traffic signal at the school's northern driveway. This driveway will serve as the main public entrance to the school as well as the Dunwoody Nature Center. The signal is part of a larger construction project that includes sidewalks and turn lanes on Roberts Drive.

The construction bid for the traffic signal portion of the project has been publically advertised and the city has received three bids for the work. The lowest qualified bid of \$171,660 was submitted by R. J. Haynie & Associates, Inc. The bid tabulation is included on the following page and the bid advertisement can be accessed from the city's website at:

<https://www.bidnetdirect.com/georgia/dunwoody/solicitations/Roberts-Drive-Signal-Bid-Package/0000206137?purchasingGroupId=58111501&origin=2>

The bid amount plus contingency and construction management fee is within the budgeted amount for this project.

### **RECOMMENDED ACTION**

Staff recommends approval of a contract for the Austin Elementary traffic signal installation in the amount of \$171,660 with an additional 10% contingency to R. J. Haynie & Associates, Inc.

**BID/PROPOSAL RESPONSES**  
CITY OF DUNWOODY

Solicitation: ITB 19-01

Date: 2-13-2019

	COMPANY	BID TOTAL
1	Wilburn Engineering	\$238,042.08
2	R.J. Haynie + Associates, Inc.	\$171,660.00
3	World Fiber Technologies, LLC	\$217,396.64
4		
5		
6		
7		
8		
9		
10		
11		
12		
13		
14		
15		
16		
17		
18		
19		
20		

TRAFFIC SIGNAL GENERAL NOTES

1. THE COMPLETE SIGNAL INSTALLATION SHALL CONFORM TO ALL APPROPRIATE PARTS OF THE MANUAL ON UNIFORM TRAFFIC CONTROL DEVICES, CURRENT EDITION; INCLUDING SUBSEQUENT PUBLISHED RULINGS.

2. SIGNAL HEADS SHALL BE ERECTED TO PROVIDE AT LEAST 17 FEET BUT NO MORE THAN 19 FEET CLEARANCE FROM BOTTOM OF SIGNAL HEADS TO TOP OF ROAD SURFACE AND A MINIMUM OF 8 FEET MEASURED HORIZONTALLY BETWEEN CENTERS OF SIGNAL FACES.

3. SHIELDED CABLE WILL BE USED FOR DETECTOR RUNS AS SHOWN ON THE DETAIL SHEET. DETECTORS SHALL HAVE SEPARATE LEAD-INS TO THE CONTROLLER CABINET.

4. THE CONTRACTOR SHALL LOCATE UNDERGROUND UTILITIES IN VICINITY OF NEW TRAFFIC SIGNAL POLES PRIOR TO ORDERING. AT THE DISCRETION OF THE ENGINEER, MINOR SHIFTS (UP TO 5 FEET, MAXIMUM) IN LOCATION OF NEW SIGNAL POLES ARE ACCEPTABLE TO AVOID UNDERGROUND UTILITIES. MINIMUM CLEARANCES FROM EDGE OF PAVEMENT SHALL BE MAINTAINED. PLACEMENT OF THE SIGNAL HEADS SHALL BE RETAINED AS SHOWN ON THE PLANS.

5. THE CONTRACTOR WILL BE RESPONSIBLE FOR ALL NEW GUYS ON EXISTING UTILITY TIMBER POLES WHEN ATTACHING SPAN WIRE OR INTERCONNECT CABLE TO THE POLES UNLESS OTHERWISE DIRECTED BY THE ENGINEER.

6. INSTALLATION IS TO BE CHECKED AND ACCEPTED BY THE CITY OF DUNWOODY TRAFFIC ENGINEER PRIOR TO FINAL ACCEPTANCE.

7. FOR STRAIN POLE FOUNDATION SIZE AND REINFORCEMENT, SEE STRAIN POLE AND MAST ARM POLE FOUNDATION SHEET. (GDOT DETAIL TS-06)

8. MATERIAL CERTIFICATION IS REQUIRED PRIOR TO BEGINNING ANY SIGNAL INSTALLATION WORK. THE CONTRACTOR SHALL FOLLOW PROCEDURES OUTLINED IN GDOT SPECIFICATIONS (WITH EXCEPTIONS AS DIRECTED BY THESE PLANS OR THE CITY OF DUNWOODY). INSTALLATION SHALL MEET CURRENT NEPA, NATIONAL ELECTRICAL CODE AND ANSI NATIONAL ELECTRICAL SAFETY CODE.

9. ATTACHMENT HEIGHTS SHALL BE FIELD DETERMINED BY INSTALLER TO PROVIDE REQUIRED SIGNAL HEAD MOUNTING HEIGHTS AND CLEARANCE FROM EXISTING UTILITIES.

10. THE CONTRACTOR SHALL REPLACE IN KIND AND SIZE, AT NO SEPARATE EXPENSE TO DUNWOODY, ANY BARRIER WALL, FENCE, DITCH PAVING, CURBING, SIDEWALK, GUTTER, SLOPE PAVEMENT, SIGNS, GUARDRAILS, LANDSCAPING, GRASSINGS, UTILITY SERVICE LINES, STORM DRAIN PIPES, MASONRY WALLS AND PAVING THAT IS REMOVED, DAMAGED OR DESTROYED DUE TO CONTRACTOR'S ACTIVITIES.

11. THE CONTRACTOR SHALL BE RESPONSIBLE FOR ALL EROSION CONTROL MEASURES TO ENSURE COMPLIANCE TO ALL STATE AND FEDERAL LAWS AND GUIDELINES. THE COST SHALL BE CONSIDERED INCIDENTAL AND BE INCLUDED IN THE OVERALL BID PRICE. NO ADDITIONAL PAYMENTS SHALL BE MADE TO THE CONTRACTOR FOR EROSION CONTROL.

12. ALL TRAFFIC MARKINGS, SYMBOLS OR STRIPING TO BE REMOVED AND/OR REPLACED SHALL BE PAID FOR IN THE TRAFFIC CONTROL LUMP SUM ITEM.

13. THE CONTRACTOR WILL BE RESPONSIBLE FOR ALL FEES ASSOCIATED WITH MODIFYING AND ESTABLISHING NEW POWER AND COMMUNICATIONS SERVICES FOR TRAFFIC SIGNALS, DETECTION SYSTEMS AND/OR CCTV CAMERAS ON THIS PROJECT. IF A UTILITY TRANSFORMER IS REQUIRED FOR TRAFFIC SIGNAL EQUIPMENT, IT IS THE RESPONSIBILITY OF THE CONTRACTOR TO INCLUDE THE COST, AS PART OF THE BID PRICE, FOR THAT TRAFFIC SIGNAL INSTALLATION, IF THE RESPECTIVE UTILITY REQUIRES PAYMENT FOR INSTALLATION.

14. THE CONTRACTOR WILL BE RESPONSIBLE FOR ALL MONTHLY POWER AND COMMUNICATION SERVICE TO THE TRAFFIC SIGNAL INSTALLATION AND SUPPORT DEVICES UNTIL THE NEW TRAFFIC SIGNAL INSTALLATION HAS SATISFACTORILY COMPLETED A TEST PERIOD, 30 DAYS OF UNINTERRUPTED OPERATION. THE CONTRACTOR WILL COMPLETE A TRANSFER OF UTILITY COST TO THE CITY OF DUNWOODY.

15. CONTRACTOR SHALL SUBMIT LOAD CALCULATIONS, SHOP DRAWINGS AND FOUNDATION DIMENSIONS OF POLES AND CATALOG CUTS OF PROPOSED SIGNAL EQUIPMENT AND ELECTRICAL/LINE HARDWARE MATERIALS TO THE CITY OF DUNWOODY FOR APPROVAL.

16. LOOP DETECTOR UNIT SHALL ENERGIZE ITS INDIVIDUAL LOOP CHANNELS NONCONCURRENTLY. DETECTOR UNIT SHALL BE FAIL SAFE (PROVIDE A CONSTANT CALL TO THE CONTROLLER IF LOOP FAILURE OCCURS).

17. CONDUIT ROUTED UNDER DRIVEWAYS OR ROADWAYS SHALL BE TYPE 3 (HDPE).

18. ALL VEHICULAR AND PEDESTRIAN SIGNALS SHALL HAVE BLACK FACES AND BLACK BACKS. ALL SIGNAL HARDWARE SHALL BE BLACK. VEHICULAR SIGNALS SHALL ALSO HAVE ALUMINUM BACKPLATES WITH 2" RETROREFLECTIVE BORDER.

19. THE CONTRACTOR WILL BE RESPONSIBLE FOR TRAFFIC CONTROL DURING CONSTRUCTION.

20. THE QUANTITIES PROVIDED IN THIS PLANS SET ARE AN ESTIMATE ONLY AND MAY NOT BE ACCURATE. IT IS THE CONTRACTOR'S RESPONSIBILITY TO ENSURE THE BID PRICE COVERS ALL MATERIALS REQUIRED TO COMPLETE THE INSTALLATION.



**WOLVERTON**  
Engineering Solutions You Can Trust  
6745 Sugarloaf Parkway • Suite 100 • Duluth, Georgia 30097  
Phone: 770-447-8999  
www.wolvertoninc.com

**BID DOCUMENTS**  
**JANUARY 11, 2019**















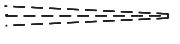
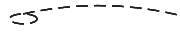



REVISION DATES

**SIGNAL PLANS**



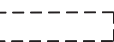
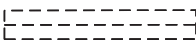
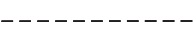





















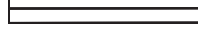

**ROBERTS DRIVE @ ROBERTS PARK ROAD**

CHECKED:	DATE:	DRAWING No.
BACKCHECKED:	DATE:	27-0001
CORRECTED:	DATE:	
VERIFIED:	DATE:	

EXISTING SIGNAL

-  CONTROLLER CABINET
-  STRAIN POLE
-  TIMBER POLE
-  DOWN GUY
-  MAST ARM
-  STREET LIGHT
-  3 SECTION HEAD
-  4 SECTION HEAD W/BACKPLATE
-  4/5 SECTION (CLUSTER/T-SHAPE) HEAD
-  OVERHEAD SIGN
-  PEDESTAL POLE
-  PED SIGNAL HEAD
-  CURB CUT RAMP
-  PULLBOX, (TYPE TO BE CALLED OUT)
-  6x6 PULSE LOOP
-  6x18 CALL LOOP
-  6x40 PRESENCE LOOP (DIPOLE)
-  6x40 PRESENCE LOOP (QUADRUPOLE)
-  CONDUIT
-  RAILROAD CONTROLLER
-  SIGN POST

PROPOSED SIGNAL

-  CONTROLLER CABINET
-  STRAIN POLE
-  TIMBER POLE
-  DOWN GUY
-  MAST ARM
-  STREET LIGHT
-  3 SECTION HEAD
-  3 SECTION HEAD W/BACKPLATE
-  4 SECTION HEAD
-  4 SECTION HEAD W/BACKPLATE
-  4/5 SECTION (CLUSTER/T-SHAPE) HEAD
-  4/5 SECTION (CLUSTER/T-SHAPE) HEAD W/ BACKPLATE
-  OVERHEAD SIGN
-  PEDESTAL POLE
-  PED SIGNAL HEAD
-  CURB CUT RAMP - (SEE ADA DETAIL)
-  PULLBOX, (TYPE TO BE CALLED OUT)
-  6x6 PULSE LOOP
-  6x18 CALL LOOP
-  6x40 PRESENCE LOOP (DIPOLE)
-  6x40 PRESENCE LOOP (QUADRUPOLE)
-  CONDUIT, (TYPE TO BE CALLED OUT)
-  RAILROAD CONTROLLER
-  SIGN POST
-  RADAR DETECTION DEVICE
-  MAGNETOMETER DETECTION DEVICE
-  VIDEO DETECTION DEVICE
-  VIRTUAL DETECTION ZONE (RADAR, VIDEO, ETC)

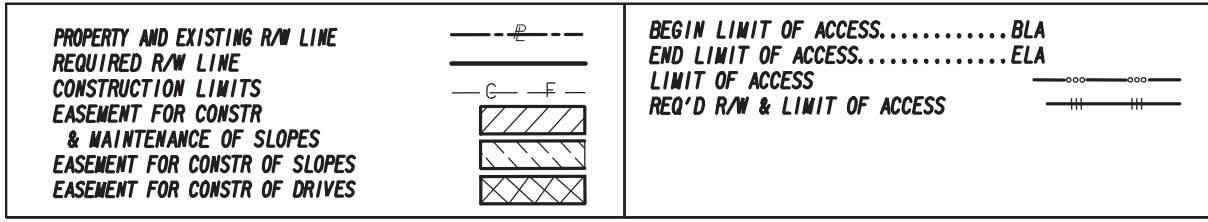

**WOLVERTON**  
 Engineering Solutions You Can Trust  
 6745 Sugarloaf Parkway • Suite 100 • Duluth, Georgia 30097  
 Phone: 770-447-8999  
 www.wolvertoninc.com

**BID DOCUMENTS**  
**JANUARY 11, 2019**

REVISION DATES		

**SIGNAL PLANS**  
**ROBERTS DRIVE @ ROBERTS PARK ROAD**

CHECKED:	DATE:	DRAWING No.
BACKCHECKED:	DATE:	27-0002
CORRECTED:	DATE:	
VERIFIED:	DATE:	



PHASING DIAGRAM

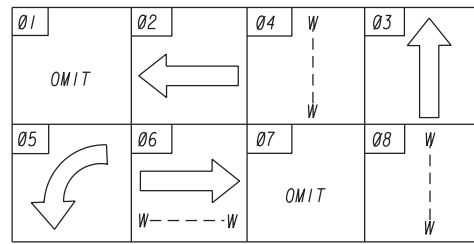

PEDESTRIAN HEADS 2" RETRO-REFLECTIVE BORDER ON BACKPLATE

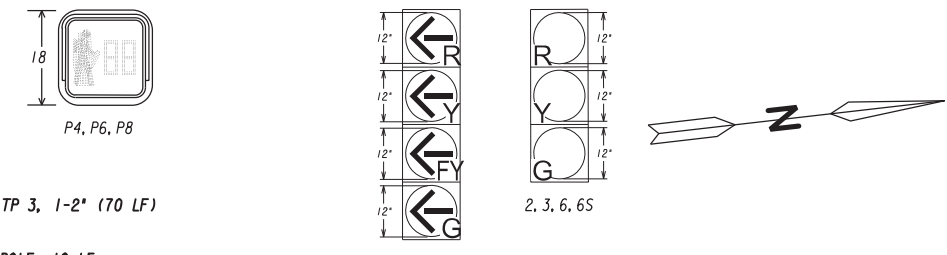

INSTALL (ON PROPOSED TIMBER POLE);  
CONDUIT, GRS, 1-1" (30 LF) (FOR POWER)

INSTALL:  
PULLBOX, TP 2  
CONDUIT, GRS, 1-1" (10 LF)  
(TO PROPOSED TIMBER POLE) (FOR POWER)

INSTALL:  
STEEL STRAIN POLE, TP IV, W/ DUAL 25'/65' MAST ARM  
(ROBERTS DRIVE STA 118+92.30, LT 35.3')  
LUMINAIRE ARM  
CCTV CAMERA, TYPE H  
LED COUNTDOWN PEDESTRIAN SIGNAL (P4)  
PUSH BUTTON STATION  
CONDUIT, NM, 3-2" (30 LF) & 2-1" (20 LF)

INSTALL:  
CONDUIT, GRS, 1-1" (35 LF)

INSTALL:  
PEDESTAL POLE, 4 LF  
POWER DISCONNECT BOX  
CONDUIT, GRS, 1-1" (15 LF)  
(FROM PEDESTAL POLE TO PROPOSED CABINET)

INSTALL:  
332A CABINET & BASE  
2070LX CONTROLLER  
4G CELLULAR ROUTER, TP B  
UNINTERRUPTIBLE POWER SUPPLY  
CONDUIT, NM, 5-2" (50 LF) & 2-1" (20 LF)  
PULLBOX, TP 4

INSTALL:  
CONDUIT, TP 3, 1-2" (70 LF)

INSTALL:  
PEDESTAL POLE, 10 LF  
LED COUNTDOWN PEDESTRIAN SIGNAL (P8)  
PUSH BUTTON STATION  
CONDUIT, NM, 2-2" (20 LF) & 1-1" (10 LF)  
PULLBOX, TP 2

INSTALL:  
CONDUIT, TP 3, 1-2" (75 LF)

INSTALL:  
CONDUIT, TP 3, 1-2" (100 LF)  
IN 3" DIRECTIONAL BORE (100 LF)

INSTALL:  
CONDUIT, TP 3, 1-2" (80 LF)

INSTALL:  
PULLBOX, TP 2

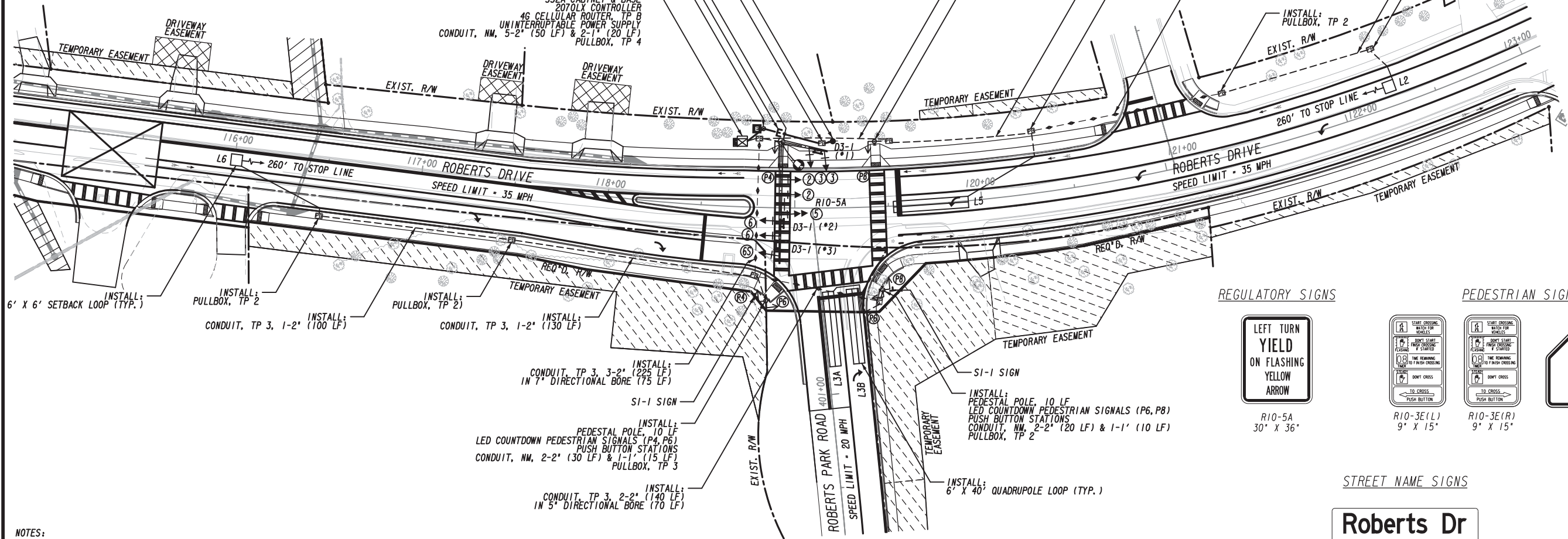

REGULATORY SIGNS



R10-5A  
30" X 36"

PEDESTRIAN SIGNS

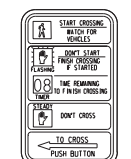

R10-3E(L)  
9" X 15"

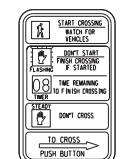

R10-3E(R)  
9" X 15"



SI-1  
36" X 36"

STREET NAME SIGNS



D3-1 (\*1)



D3-1 (\*2)



D3-1 (\*3)

NOTES:

1. ALL MAST ARM POLES AND MAST ARMS SHALL BE POWDER COATED BLACK.
2. THE MAST ARM ON THE SOUTHWEST CORNER SHALL HAVE ADDITIONAL HEIGHT TO ACCOMMODATE CCTV CAMERA.
2. SEE SHEET 27-0005 FOR INTERSECTION DETAIL.

SIGNAL LEGEND

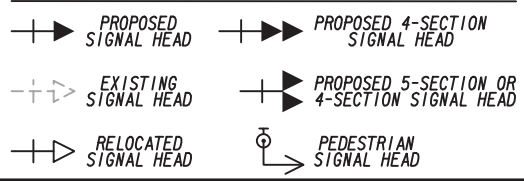

DETECTION LEGEND

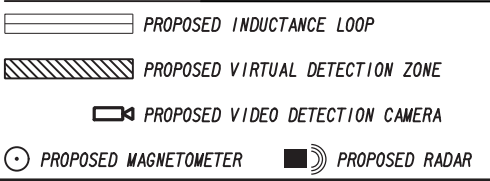

**WOLVERTON**  
Engineering Solutions You Can Trust

6745 Sugarloaf Parkway • Suite 100 • Duluth, Georgia 30097  
Phone: 770-447-8999  
www.wolvertoninc.com

BID DOCUMENTS  
JANUARY 11, 2019

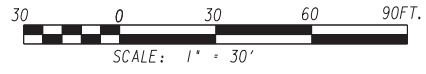

REVISION DATES

NO.	DATE	DESCRIPTION

SIGNAL PLANS

ROBERTS DRIVE @ ROBERTS PARK ROAD

CHECKED:	DATE:	DRAWING No.
BACKCHECKED:	DATE:	27-0003
CORRECTED:	DATE:	
VERIFIED:	DATE:	

LIST OF MATERIALS

MATERIALS	UNIT	QUANTITY
<b>CONTROLLER CABINET ASSEMBLIES</b>		
A. CONTROLLER UNIT, MODEL 2070LY	EA	1
D. CABINET ASSEMBLY, MODEL 332A	EA	1
F. SWITCH PACK	EA	8
G. DC ISOLATOR	EA	3
H. LOOP DETECTOR, 2-CHANNEL	EA	4
K. 2010 CONFLICT MONITOR, EXTENDED FEATURES (ETHERNET)	EA	1
L. AUXILIARY LOAD BAY	EA	1
M. UNINTERRUPTIBLE POWER SUPPLY EXTERNAL MOUNTED, CABINET (PER GDOT SPECIFICATIONS)	EA	1
332 PREFABRICATED CONTROLLER CABINET BASE W/UPS EXTENSION	EA	1
LOOP/LED LEAD-IN WIRE (SHIELDED, TWISTED/1000 FT) 3 PAIR, 14 AWG	REEL	2
SIGNAL CABLE (14 AWG) 7 CONDUCTOR, PER 1000 FT.	REEL	1
LOOP DETECTOR WIRE (14 AWG, STRANDED/1000 FT)	REEL	2
ONE-WAY, 3-SECTION, 12" LED SIGNAL HEAD (BLACK HOUSING WITH BLACK FRONT, PLASTIC)	EA	7
ONE-WAY, 4-SECTION, 12" LED SIGNAL HEAD (BLACK HOUSING WITH BLACK FRONT, PLASTIC)	EA	1
1-SECTION, 18" LED COUNTDOWN PEDESTRIAN SIGNAL HEAD, FULL HAND/MAN OVERLAP 9" HIGH, NUMBERS & 12" SYMBOLS	EA	6
PEDESTRIAN PUSH BUTTON STATION ASSEMBLY 9" x 15", W/SINGLE PUSH BUTTON ADAPTER FOR 4" DIA PEDESTRIAN POLE, ADJUSTABLE	EA	2
PEDESTRIAN PUSH BUTTON STATION ASSEMBLY 9" x 15", W/DOUBLE PUSH BUTTON ADAPTER FOR 4" DIA PEDESTRIAN POLE, ADJUSTABLE	EA	2
PEDESTRIAN PUSH BUTTON STATIONS, W/BUTTONS AND SIGNS: 9" x 15", R10-3e, (LEFT OR RIGHT, COUNTDOWN)	EA	6
BACK PLATE FOR ONE-WAY, 3-SECTION, 12" SIGNAL HEAD, W/RETRO REFLECTIVE TAPE	EA	7
BACK PLATE FOR ONE-WAY, 4-SECTION, 12" SIGNAL HEAD, W/RETRO REFLECTIVE TAPE	EA	1
HARDWARE FOR MAST ARM MOUNTING	EA	8
HARDWARE FOR PEDESTAL POLE, TOP POST MOUNTING, ONE-WAY BRACKET ASSEMBLY	EA	1
HARDWARE FOR PEDESTAL POLE, TOP POST MOUNTING, TWO-WAY BRACKET ASSEMBLY	EA	2
HARDWARE FOR SIDE-OF-POLE MOUNTING, ONE-WAY BRACKET ASSEMBLY; CONCRETE, TIMBER, STEEL POLE	EA	1
PEDESTAL POLE, 10 FT. & SQUARE BASE	EA	3
PEDESTAL POLE, 4 FT. & SQUARE BASE	EA	1
PULLBOX, PB-2	EA	8
PULLBOX, PB-3	EA	3
LOOP SAW CUT	LF	595
CONDUIT, 1"	LF	75
CONDUIT, 2"	LF	150
R10-5A, LEFT TURN YIELD ON FLASHING YELLOW ARROW	EA	1
POWER DISCONNECT BOX	EA	1
MISCELLANEOUS MATERIALS NEEDED TO COMPLETE INSTALLATION	LUMP	LUMP

LIST OF MATERIALS IS "FOR INFORMATION ONLY" AND SHOULD BE VERIFIED BY THE CONTRACTOR.

GENERAL NOTES

- EACH SIGN SHALL CONTAIN A MINIMUM OF (2) HANGERS OR BRACKETS.
- SIGN LEGEND SHALL BE 11-IN. UPPER CASE & 8-IN. LOWER CASE SERIES "D" LETTERS. ALL ARROWS SHALL BE 8-IN. TALL & 12-IN. LONG.
- EACH SIGN SHALL CONTAIN 1 1/2-IN. RADII.
- EACH SIGN SHALL BE MADE OF ONE CONTINUOUS PIECE OF ALUMINUM.
- SIGNS SHALL HAVE STANDARD REFLECTORIZED INTERSTATE GREEN BACKGROUND WITH WHITE REFLECTORIZED LEGENDS, BORDERS AND ARROWS.
- FOR SIGNS THAT ARE 72-IN. OR GREATER THEY SHALL CONTAIN A MINIMUM OF THREE (3) HANGERS OR BRACKETS.

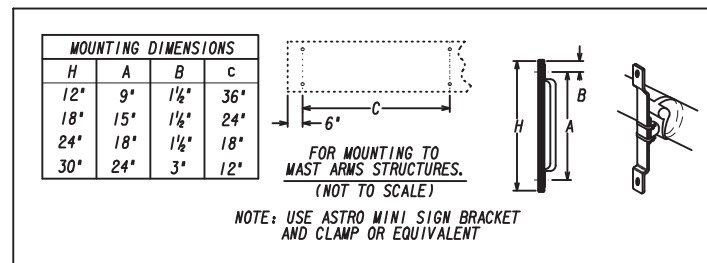

332 CABINET INPUT ASSIGNMENT

SLOT	1	2	3	4	5	6	7	8	9	10	11	12	13	14	
UPPER INPUT FILE															
CHANNEL 1	TYPE	DET	DET	DET	DET	DET	DET	DET	DET	TBA	TBA	DC	DC	DC	
	CARD		2-CH			2-CH						DC 150	DC 150	DC 150	
	CI PIN	56	39	63	47	58	41	65	49	60		80	67	68	81
	FUNCTION		L2			L3A						ADVANCE		Ø 6 PED	FLASH
FIELD TERM	TB2 1, 2	TB2 5, 6	TB2 9, 10	TB4 1, 2	TB4 5, 6	TB4 9, 10	TB6 1, 2	TB6 5, 6	TB6 9, 10			TB8 4, 6	TB8 7, 9	N/C	
DETECTOR	1	3	5	7	9	11	13	15	17			PED 2	PED 6		
ASSIGNED	1	2	2	2	3	4	4	4	1				Ø6		
CHANNEL 2	TYPE	DET	DET	DET	DET	DET	DET	DET	DET	TBA	TBA	DC	DC	DC	
	CARD					L3B						ENABLE	Ø 4 PED	Ø 8 PED	STOP TIME
	CI PIN	56	43	76	47	58	45	78	49	62		53	69	70	82
	FUNCTION					L3B						ENABLE	Ø 4 PED	Ø 8 PED	STOP TIME
FIELD TERM	TB2 3, 4	TB2 7, 8	TB2 11, 12	TB4 3, 4	TB4 7, 8	TB4 11, 12	TB6 3, 4	TB6 7, 8	TB6 11, 12			TB8 5, 6	TB8 8, 9	N/C	
DETECTOR	1	4	6	7	9	12	14	15	18			PED 4	PED 8		
ASSIGNED	1	2	2	2	3	4	4	4	3			Ø4	Ø8		
LOWER INPUT FILE															
CHANNEL 1	TYPE	DET	DET	DET	DET	DET	DET	DET	DET	TBA	TBA	DC	DC	DC	
	CARD	2-CH	2-CH												
	CI PIN	55	40	64	48	57	42	66	50	59		54	71	72	51
	FUNCTION	L5	L6										EVA	EV8	RR 1
FIELD TERM	TB3 1, 2	TB3 5, 6	TB3 9, 10	TB5 1, 2	TB5 5, 6	TB5 9, 10	TB7 1, 2	TB7 5, 6	TB7 9, 10			TB9 4, 6	TB9 7, 9	TB9 10, 12	
DETECTOR	19	21	23	25	29	31	33	35	37			SPARE 2	PRE 3	PRE 4	PRE 1
ASSIGNED	5	6	6	6	7	8	8	8	5						
CHANNEL 2	TYPE	DET	DET	DET	DET	DET	DET	DET	DET	TBA	TBA	DC	DC	DC	
	CARD											SPARE 3	EVC	EVD	RR 2
	CI PIN	55	44	77	48	57	46	79	50	61		75	73	74	52
	FUNCTION											SPARE 3	EVC	EVD	RR 2
FIELD TERM	TB3 3, 4	TB3 7, 8	TB3 11, 12	TB5 3, 4	TB5 7, 8	TB5 11, 12	TB7 3, 4	TB7 7, 8	TB7 11, 12			TB9 5, 6	TB9 8, 9	TB9 11, 12	
DETECTOR	19	22	24	25	29	32	34	35	38			PRE 5	PRE 6	PRE 2	
ASSIGNED	5	6	6	6	7	8	8	8	7						

DETAILS OF OVERHEAD STREET NAME SIGNS

ALL DIMENSIONS IN INCHES UNLESS OTHERWISE SPECIFIED.

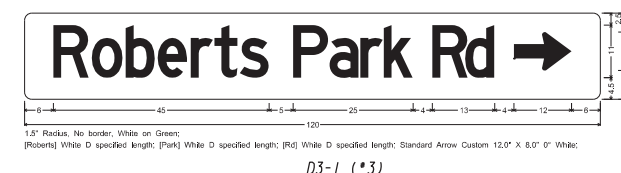
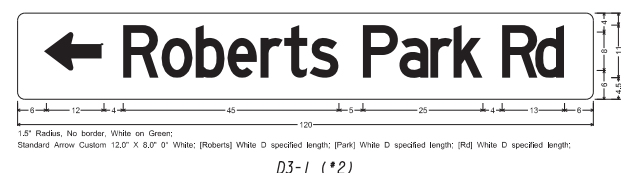
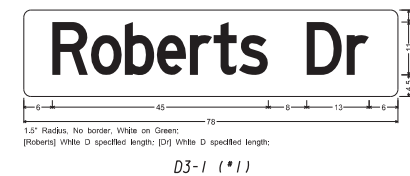

**WOLVERTON**  
Engineering Solutions You Can Trust  
6745 Sugarloaf Parkway • Suite 100 • Duluth, Georgia 30097  
Phone: 770-447-8999  
www.wolvertoninc.com

**BID DOCUMENTS**  
**JANUARY 11, 2019**

REVISION DATES

SIGNAL PLANS

ROBERTS DRIVE @ ROBERTS PARK ROAD

CHECKED:	DATE:	DRAWING No.
BACKCHECKED:	DATE:	
CORRECTED:	DATE:	
VERIFIED:	DATE:	

27-0004

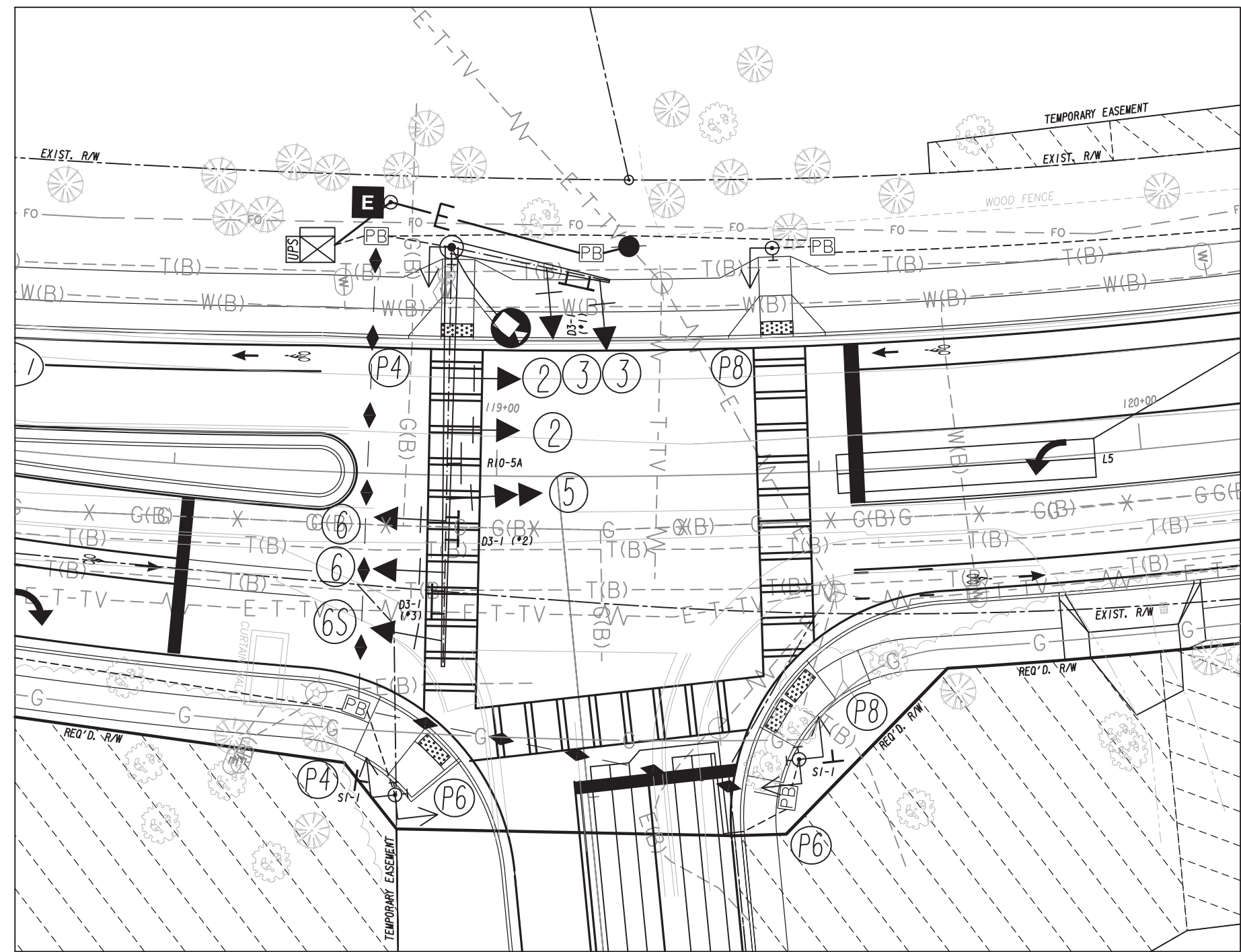

INTERSECTION DETAIL

BID DOCUMENTS  
JANUARY 11, 2019

**SIGNAL LEGEND**

	PROPOSED SIGNAL HEAD		PROPOSED 4-SECTION SIGNAL HEAD
	EXISTING SIGNAL HEAD		PROPOSED 5-SECTION OR 4-SECTION SIGNAL HEAD
	RELOCATED SIGNAL HEAD		PEDESTRIAN SIGNAL HEAD

**DETECTION LEGEND**

	PROPOSED INDUCTANCE LOOP
	PROPOSED VIRTUAL DETECTION ZONE
	PROPOSED VIDEO DETECTION CAMERA
	PROPOSED MAGNETOMETER
	PROPOSED RADAR

**WOLVERTON**  
Engineering Solutions You Can Trust

6745 Sugarloaf Parkway • Suite 100 • Duluth, Georgia 30097  
Phone: 770-447-8999  
www.wolvertoninc.com

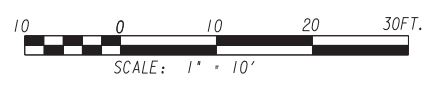

**REVISION DATES**

NO.	DATE	DESCRIPTION

**SIGNAL PLANS**  
ROBERTS DRIVE @ ROBERTS PARK ROAD

CHECKED:	DATE:	DRAWING No.
BACKCHECKED:	DATE:	27-0005
CORRECTED:	DATE:	
VERIFIED:	DATE:	



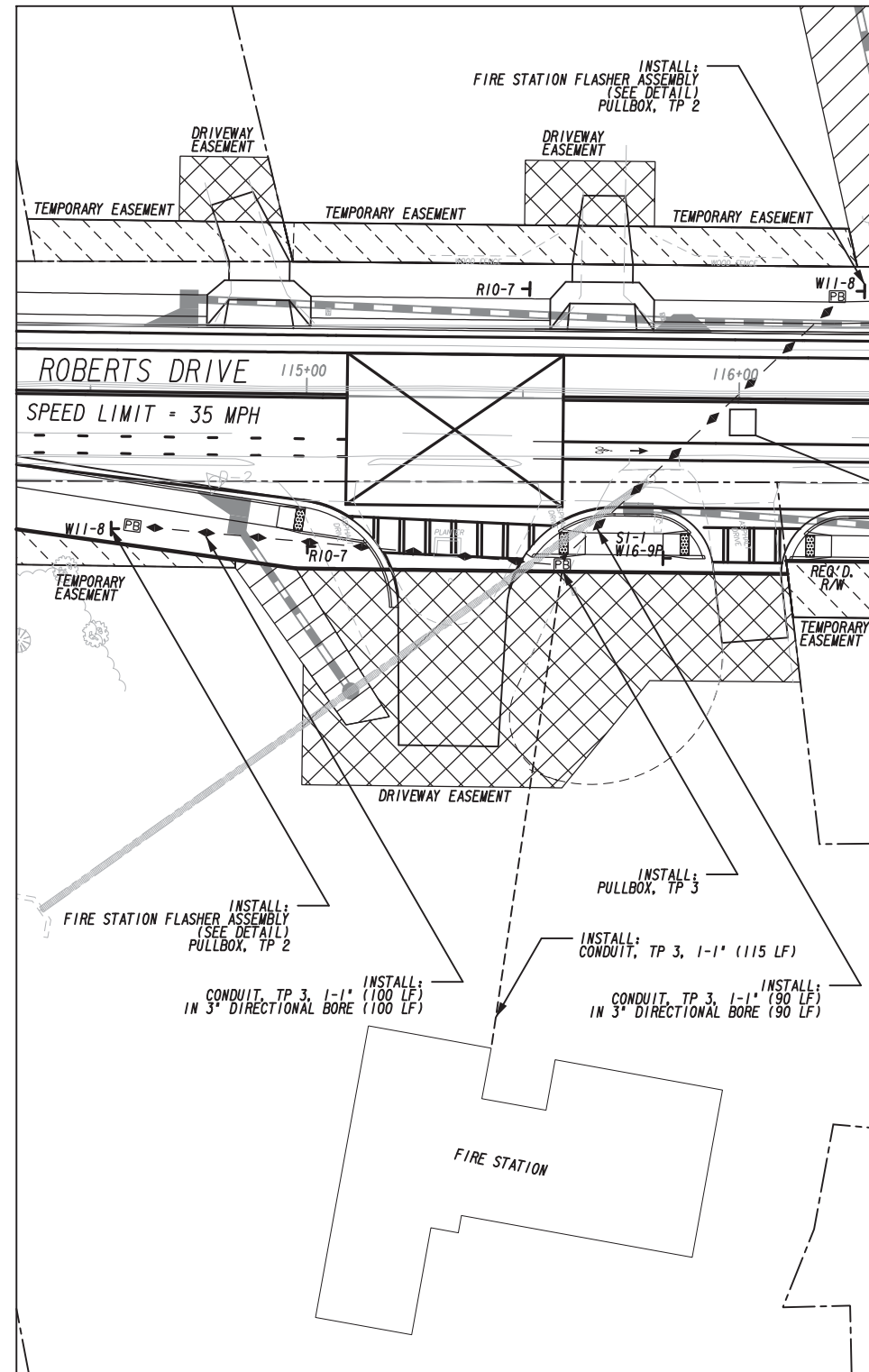

FIRE STATION FLASHER DETAIL



FIRE STATION FLASHER ASSEMBLY

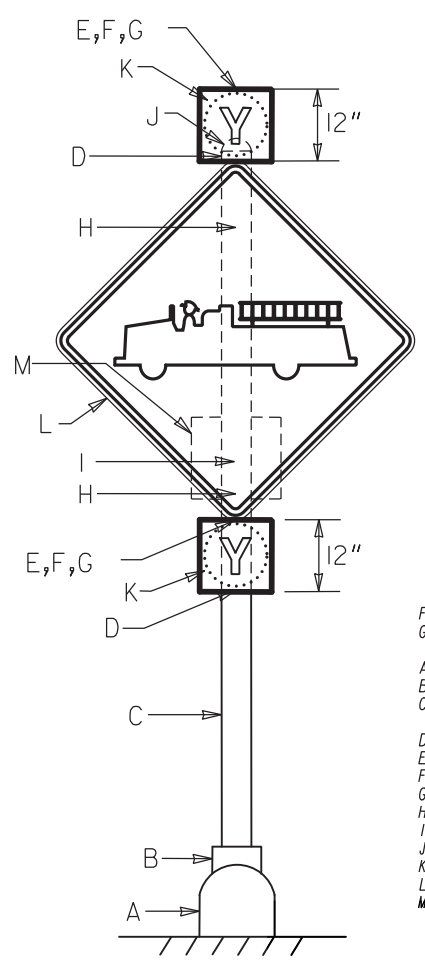

W11-8  
36" X 36"

FIRE STATION FLASHER ASSEMBLY PARTS LIST

- FLASHING WARNING ASSEMBLY SHALL INCLUDE PEDESTAL POLE, FOUNDATION, GROUND ROD, SIGNAL HEADS, SIGNS AND BRACKETS.
- A. 1 EA ALUMINUM SQUARE BASE ASSY. W/ALUMINUM DOOR, PELCO PB-5335, OR EQUIV.
  - B. 1 EA. POLE COLLAR ASSY., PELCO PB-5325, OR EQUIV.
  - C. 1 EA. SPUN ALUMINUM POLE, SCH 40, 13 FEET LONG, 4 1/2" O.D. X .237 WALL, PELCO PB-5100-13, OR EQUIV.
  - D. 2 EA. SIGNAL BRACKET ASSY., 4" POLE SIDE MOUNT, PELCO SE-5053, OR EQUIV.
  - E. 2 EA. SIGNAL CLOSURE CAP, 1 1/2" X 2" THREADED, PELCO SE-0442, OR EQUIV.
  - F. 2 EA. NEOPRENE GASKET, PELCO SE-0354, OR EQUIV.
  - G. 2 EA. HEX NUT, 1 1/2", PELCO SE-4017, OR EQUIV.
  - H. 2 EA. U-BOLT SIGN CLAMP, PELCO SH-0206, OR EQUIV.
  - I. 1 EA. CABINET MOUNTING ASSY, 4" POLE, PELCO SE-1100 OR EQUIV.
  - J. 1 EA. POLE CAP, ALUM., ACORN TYPE, PELCO PB-5401, OR EQUIV.
  - K. 2 EA. 1-SECTION, 12" TRAFFIC SIGNAL HEAD, PLASTIC, BLACK, W/5MM PIXELATED LEDS
  - L. 1 EA. W11-8 SIGN, 36" X 36", TP 2 MATL, REFL SHEETING TP 9
  - M. FLASHER CONTROL CABINET ASSY., PAGER PROGRAMMABLE (PER CITY OF DUNWOODY SPEC.)

**FIRE STATION FLASHER SPECIFICATIONS:**

CABINET ASSEMBLY WITH PAGER-PROGRAMMABLE TIME SWITCH; CABINET ASSEMBLY SHALL INCLUDE A 0.125-INCH OR THICKER SHEET ALUMINUM CABINET AND HAVE A SMOOTH, UNIFORM, NATURAL FINISH. ALL EXTERNAL WELDS SHALL BE MADE BY USING THE HELIARC WELDING METHOD, WHEREAS INTERNAL WELDS SHALL BE MADE BY USING THE WIRE WELDING METHOD. ALL WELDS SHALL BE NEATLY FORMED AND FREE OF CRACKS, BLOW-HOLES, AND OTHER IRREGULARITIES. EXTERNAL SPOT WELDING IS NOT ACCEPTABLE. ALL EXTERNAL JOINTS SHALL BE WELDED.

THE CABINET DIMENSIONS SHALL BE APPROXIMATELY 14 INCHES HIGH X 14 INCHES WIDE X 7 INCHES DEEP. THE DOOR SHALL BE FURNISHED WITH A NEOPRENE GASKET THAT SHALL FORM A WEATHER TIGHT SEAL BETWEEN THE CABINET AND DOOR. THE DOOR SHALL BE HINGED ON ONE SIDE. THE LOCK MOUNTED ON THE INSIDE OF THE DOOR SHALL BE A CORBIN PIN TUMBLER TYPE LOCK WITH A NUMBER 2 KEY.

THE EQUIPMENT SHALL BE MOUNTED ON A 0.125-IN. THICK ALUMINUM BACK PANEL MEASURING APPROXIMATELY 13 IN. X 13 IN. PANELS ARE TO BE MOUNTED ON STAND OFFS PRESSED THROUGH THE BACK WALL OF THE ENCLOSURE.

A BARRIER TYPE EIGHT POSITION TERMINAL BLOCK SHALL BE USED TO TERMINATE ALL WIRES. THE TERMINATIONS SHALL BE AS FOLLOWS: 1) AC+; 2) AC-; 3) NOT USED; 4) NEUTRAL L-1; 5) NEUTRAL L-2; 6) LOAD 1; 7) LOAD 2; 8) NOT USED. ALL TERMINALS SHALL BE CLEARLY MARKED ON THE PANEL ADJACENT TO THE TERMINAL BLOCK EITHER BY ETCHING, PERMANENT LABEL, OR A SILK SCREENING PROCESS. ALL NEUTRAL AND EARTH GROUND TERMINALS SHALL BE BONDED TOGETHER. (FLOATING NEUTRALS ARE NOT ACCEPTABLE).

EACH CABINET SHALL BE SUPPLIED WITH AN EXTERNAL ANTENNA. THE ANTENNA SHALL HAVE A MINIMUM GAIN OF 3DB AND BE HOUSED IN A PVC PIPE WITH A MEYERS HUB FOR MOUNTING. THE ANTENNA SHALL HAVE A MINIMUM OF FIFTEEN FEET OF COAX CABLE. A BNC (OR EQUAL) CONNECTOR SHALL BE INSTALLED ON THE COAX CABLE FOR CONNECTION TO THE TIME SWITCH.

THE FOLLOWING EQUIPMENT SHALL BE MOUNTED ON THE CABINET PANEL: RTC CPR2101 PROGRAMMABLE TIME SWITCH, WITH PLUG IN CONNECTOR; SURGE ARRESTOR (EDCO SPA-100-T) OR EQUIVALENT; 115 VAC CIRCUIT BREAKER (SQUARE "D" BRAND 00U 115 SERIES OR EQUIVALENT); FLASHER BRACKET WITH NEMA FLASHER SOCKET BASE; COPPER GROUNDING LUG (FOR # 6 COPPER WIRE OR LARGER).

THE CABINET ASSEMBLY SHALL BE MOUNTED TO THE PEDESTAL POLE WITH A PELCO SE-11 OR EQUIVALENT MOUNTING ASSEMBLY. CABLES SHALL ENTER DIRECTLY FROM THE POLE THROUGH THE MOUNTING ASSEMBLY ON THE BACK OF THE CABINET. EXTERNAL CONDUIT SHALL NOT BE USED ON THE CABINET ASSEMBLY.

THE RTC CPR2101 PROGRAMMABLE TIME SWITCH SHALL BE PROVIDED TO THE CITY OF DUNWOODY TRAFFIC SIGNAL ENGINEER FOR PROGRAMMING PRIOR TO INSTALLATION.

THE FLASHER SIGNAL HEADS SHALL BE 12" EXPANDED VIEW LED, PLASTIC (BLACK HOUSING) W/GELCORE OR OTHER CITY OF DUNWOODY APPROVED PIXELLED LED MODULE.

POWER BREAKER/DISCONNECT SHALL BE INSTALLED ON THE POWER POLE, PER GDOT STANDARDS, TO POWER THE CONTROL CABINET ATTACHED TO THE FIRE STATION FLASHER PEDESTAL POLE.

**SIGNAL LEGEND**

	PROPOSED SIGNAL HEAD		PROPOSED 4-SECTION SIGNAL HEAD
	EXISTING SIGNAL HEAD		PROPOSED 5-SECTION OR 4-SECTION SIGNAL HEAD
	RELOCATED SIGNAL HEAD		PEDESTRIAN SIGNAL HEAD

**DETECTION LEGEND**

	PROPOSED INDUCTANCE LOOP		PROPOSED VIRTUAL DETECTION ZONE
	PROPOSED VIDEO DETECTION CAMERA		PROPOSED MAGNETOMETER
	PROPOSED RADAR		

**WOLVERTON**  
Engineering Solutions You Can Trust

6745 Sugarloaf Parkway • Suite 100 • Duluth, Georgia 30097  
Phone: 770-447-8999  
www.wolvertoninc.com

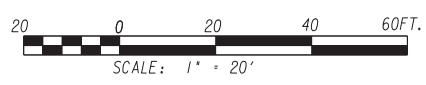

**REVISION DATES**

**SIGNAL PLANS**  
ROBERTS DRIVE @ ROBERTS PARK ROAD

CHECKED:	DATE:	DRAWING No.
BACKCHECKED:	DATE:	27-0006
CORRECTED:	DATE:	
VERIFIED:	DATE:	



# ITB 19-01: ROBERTS DRIVE SIGNAL INSTALLATION

## ADDENDUM #1, February 6, 2019

### The Bid documents have been modified as follows:

1. Are there any major underground utilities in the project limits? **RESPONSE:** See attached Utility drawings furnished for your information/reference only. Contractor shall be responsible to coordinate required utility re-locations and "Call Before You Dig".
2. Where is the location of the existing power panel that is going to feed the flashers? Outside or Inside? **RESPONSE:** Use the same power source as the signal cabinet. See attached drawing for more details. (See attached plans: Roberts Drive Boring and Roberts Signal dated Feb. 5, 2019)
3. Is there enough space in the existing power panel for the additional circuit? **RESPONSE:** YES
4. Is there a particular brand or model of a 4G Cellular Router that the city prefers? **RESPONSE:** N/A. This device has been omitted from the plan.
5. Who is the city's service provider of cellular service for the routers? **RESPONSE:** N/A. The wireless router is no longer required due to fiber optic cable drop/extension from the adjacent traffic signal at Roberts/Chamblee-Dunwoody Road.
6. Please confirm that all post mounted signs are excluded from the traffic signal scope. **RESPONSE:** Bidders shall include the signs noted on Sheets 27-0003 (R10-5A, R10-3E(L), R10-3(R), S1-1 and D3-1 (1 thru 3)) and 27-0004.
7. Please confirm if the city wants the fire station flasher poles are to black also. **RESPONSE:** YES.
8. Please confirm if the flasher time switch has to be pager programmable or will the city take in consideration a time switch that is not pager programmable? **RESPONSE:** This item has been removed from the project scope. Do not include in your bid proposal.
9. Please confirm that the CPR 2102 is the correct choice for this application. The CPR 2102 is a pager programmable time switch which is intended to run schedules. **RESPONSE:** This item has been removed from the project scope. Do not include in your bid proposal.
10. We have a signal contactor that would like to put in a bid on the Roberts Drive Signal Project as a subcontractor to us -- they do not want to be the Prime for this project. The bid documents have a 50% participation requirement for the prime contractor and since we do not perform signal work in-house can we do one of the following to satisfy the requirement:
  - a. Purchase all the materials for the project and install the Mast arm bases, leaving signal install to our sub.. or.... **RESPONSE:** No
  - b. Utilize an "Employee Lease Agreement" for the entirety of the signal scope? We can provide an example of this option if you like. **RESPONSE:** No
11. The fire station flasher assembly calls for a programmable pager (27-006). Can the city give us information on what programmable pager they need for this? **RESPONSE:** This item has been removed from the project scope. Do not include in your bid proposal.
12. For the fire station flasher assembly what is the desired power method and is there any information on where to get power from if AC is desired? **RESPONSE:** AC power will come from the signal cabinet via conduit. See drawing per Note 2 above.

ITB 19-01, Roberts Drive Signal Installation  
ADENDUM #1, Feb. 5, 2019

13. The completion time is stated as 180 calendar days from NTP. There are currently two GDOT approved pole manufacturers for mast arm fabrication. The manufacturer with the shortest lead time is 22 weeks to include powder coating. The other manufacturer is quoting 36 – 38 weeks lead time. The lead time for acquiring submittal documents ranges from 1 – 3 weeks between the two. With best possible case scenario of 22 weeks & 2 weeks for submittal documents, 168 calendar days of the allotted 180 days would be used. This does not include the amount of time the City would need to approve or reject the submittals provided. It is highly unlikely enough time would be added to accommodate the second manufacturer's lead time, but would the City consider allotting 220 – 240 calendar days for construction? **RESPONSE:** *The new Austin Elementary School opens on January 2, 2020. The new signal must be operational by then, including 30-day Burn-In. Contract duration shall be revised to 240 days.*
14. The notes for the fire station flasher state the power breaker/disconnect shall be installed on the power pole. Is the contractor to establish a new service point for these flashers or install conduit to the service point for the traffic signal? **RESPONSE:** *The power for the flashers will come from the new signal cabinet.*
15. Where does the conduit to the fire station from the Pull Box, TP 3 terminate? **RESPONSE:** *The conduit to the fire station has been omitted.* Should a pull box be installed outside the fire station for termination by others? **RESPONSE:** *No.* Are the flashers to be push button activated in conjunction with the RTC programmable time switch? **RESPONSE:** *Yes. There will be a wireless push button mounted on the inside wall of the fire station at the truck bays. The RTC programmable switch has been omitted from the scope.*

**Attachments:**

*Utility Plans, 24-000 thru 24-0006, dated 01.22.2019 (for Reference/Information only)*  
*Roberts Drive additional boring/conduit, dated 02.05.2019*  
*Roberts Signal (Fire Station Flasher Assembly), dated 02.05.2019*







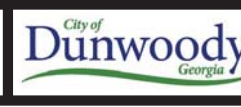

NOTE: PROPOSED UTILITY WORK SHOWN FOR INFORMATIONAL PURPOSES ONLY. UTILITIES TO BE RELOCATED BY UTILITY OWNERS.

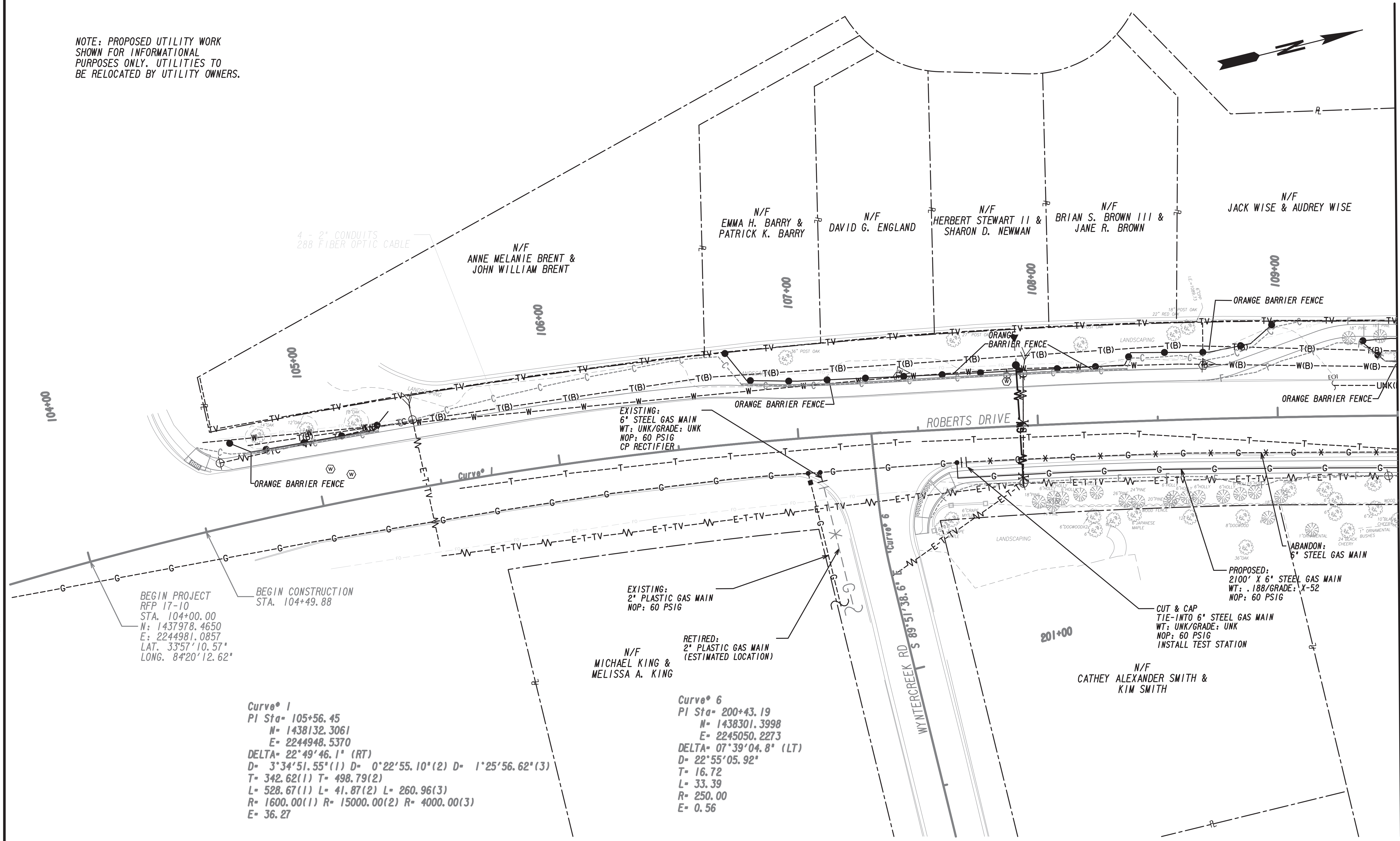

BEGIN PROJECT RFP 17-10 STA. 104+00.00  
 N: 1437978.4650  
 E: 2244981.0857  
 LAT. 33°57'10.57"  
 LONG. 84°20'12.62"

**Curve 1**  
 PI Sta- 105+56.45  
 N= 1438132.3061  
 E= 2244948.5370  
 DELTA= 22°49'46.1" (RT)  
 D= 3'34'51.55"(1) D= 0'22'55.10"(2) D= 1'25'56.62"(3)  
 T= 342.62(1) T= 498.79(2)  
 L= 528.67(1) L= 41.87(2) L= 260.96(3)  
 R= 1600.00(1) R= 15000.00(2) R= 4000.00(3)  
 E= 36.27

**Curve 6**  
 PI Sta- 200+43.19  
 N= 1438301.3998  
 E= 2245050.2273  
 DELTA= 07°39'04.8" (LT)  
 D= 22°55'05.92"  
 T= 16.72  
 L= 33.39  
 R= 250.00  
 E= 0.56

PROPERTY AND EXISTING R/W LINE	---
REQUIRED R/W LINE	---
CONSTRUCTION LIMITS	---
EASEMENT FOR CONSTR & MAINTENANCE OF SLOPES	---
EASEMENT FOR CONSTR OF SLOPES	---
EASEMENT FOR CONSTR OF DRIVES	---

BEGIN LIMIT OF ACCESS.....BLA	---
END LIMIT OF ACCESS.....ELA	---
LIMIT OF ACCESS	---
REQ'D R/W & LIMIT OF ACCESS	---
ORANGE BARRIER FENCE	---
ESA - ENV. SENSITIVE AREA	---
(SEE ERIT TABLE)	---

**WOLVERTON**  
 Engineering Solutions You Can Trust  
 6745 Sugarloaf Parkway • Suite 100 • Duluth, Georgia 30097  
 Phone: 770-447-8999  
 www.wolvertoninc.com

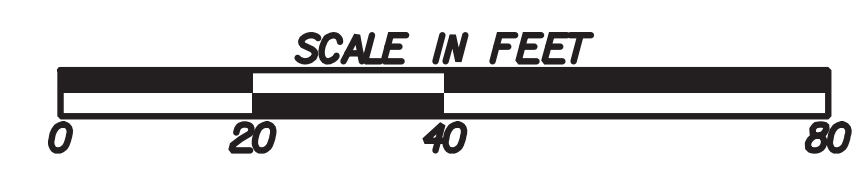

REVISION DATES	

**CITY OF DUNWOODY**  
 UTILITY PLANS  
 ROBERTS DRIVE

CHECKED: JKY	DATE: 01/08/19	DRAWING No.
BACKCHECKED: CBR	DATE: 01/10/19	24-0001
CORRECTED: LGC	DATE: 01/22/19	
VERIFIED: CBR	DATE: 01/22/19	

MATCH LINE STA. 109+50.00  
SEE DRAWING No. 24-0002



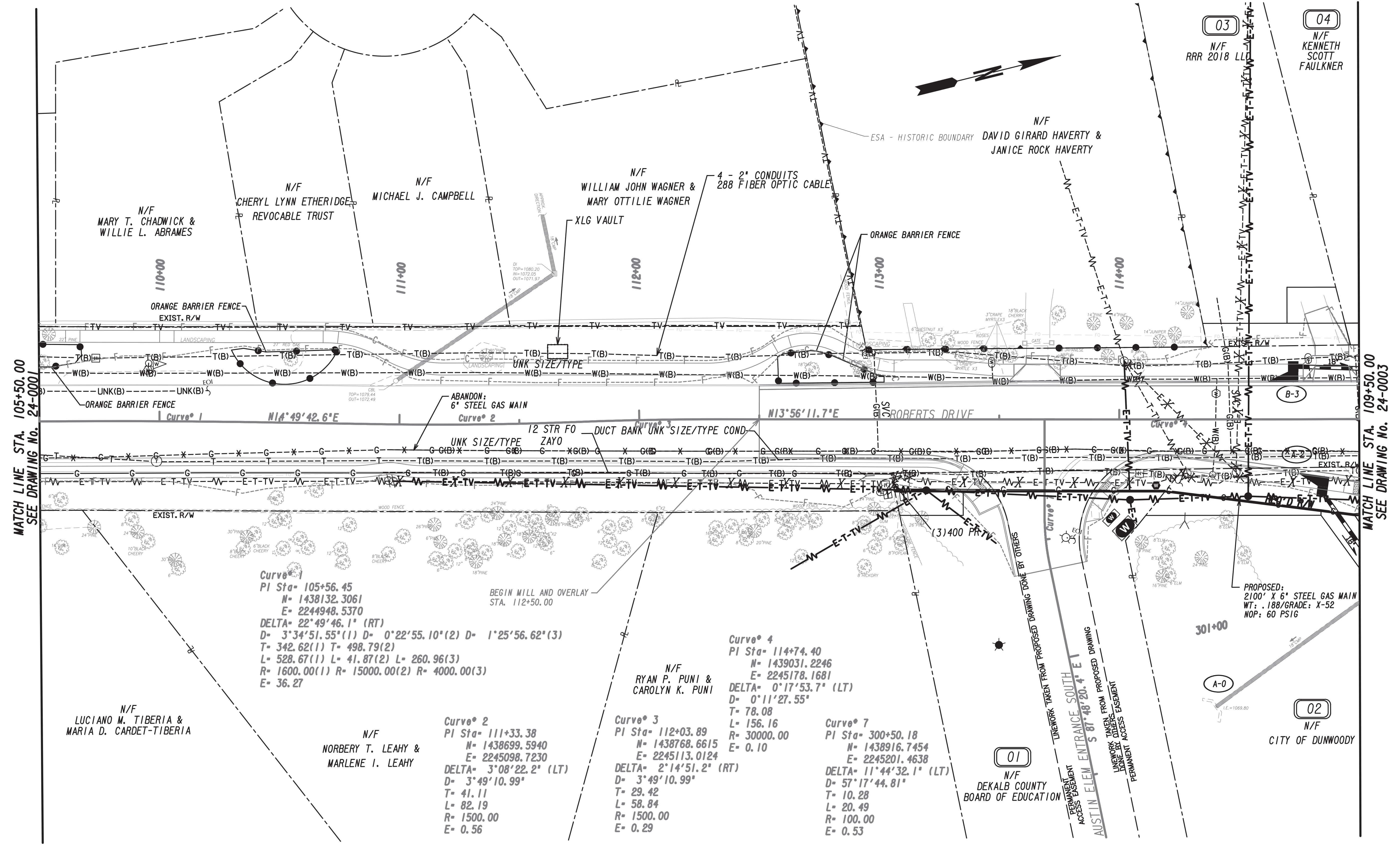

MATCH LINE STA. 105+50.00  
SEE DRAWING No. 24-0001

MATCH LINE STA. 109+50.00  
SEE DRAWING No. 24-0003

PROPERTY AND EXISTING R/W LINE	
REQUIRED R/W LINE	
CONSTRUCTION LIMITS	
EASEMENT FOR CONSTR & MAINTENANCE OF SLOPES	
EASEMENT FOR CONSTR OF SLOPES	
EASEMENT FOR CONSTR OF DRIVES	

BEGIN LIMIT OF ACCESS.....BLA	
END LIMIT OF ACCESS.....ELA	
LIMIT OF ACCESS	
REQ'D R/W & LIMIT OF ACCESS	
ORANGE BARRIER FENCE	
ESA - ENV. SENSITIVE AREA	
(SEE ERIT TABLE)	

**WOLVERTON**  
Engineering Solutions You Can Trust

6745 Sugarloaf Parkway • Suite 100 • Duluth, Georgia 30097  
Phone: 770-447-8999  
www.wolvertoninc.com

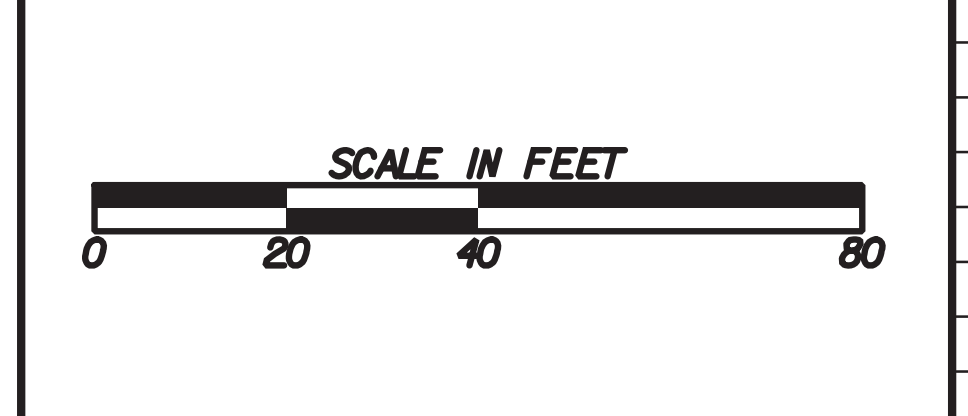

REVISION DATES	

<b>CITY OF DUNWOODY</b>			
UTILITY PLANS ROBERTS DRIVE			
CHECKED: JKY	DATE: 01/08/19	DRAWING No.	
BACKCHECKED: CBR	DATE: 01/10/19	<b>24-0002</b>	
CORRECTED: LGC	DATE: 01/22/19		
VERIFIED: CBR	DATE: 01/22/19		



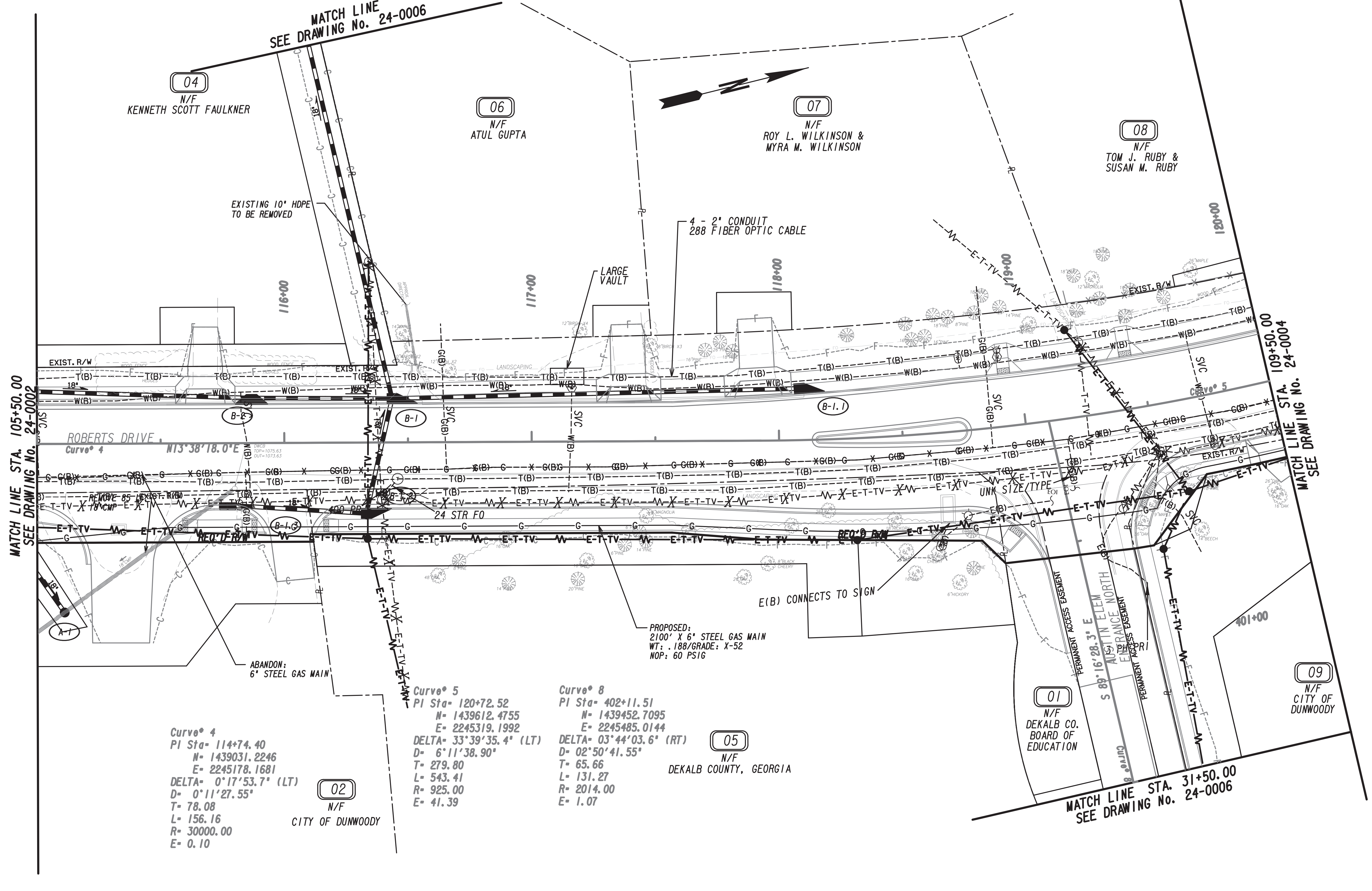
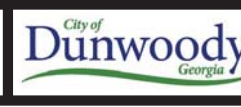

PROPERTY AND EXISTING R/W LINE  
 REQUIRED R/W LINE  
 CONSTRUCTION LIMITS  
 EASEMENT FOR CONSTR  
 & MAINTENANCE OF SLOPES  
 EASEMENT FOR CONSTR OF SLOPES  
 EASEMENT FOR CONSTR OF DRIVES

--- BLA  
 --- ELA  
 --- LIMIT OF ACCESS  
 --- REQ'D R/W & LIMIT OF ACCESS  
 --- ORANGE BARRIER FENCE  
 --- ESA - ENV. SENSITIVE AREA  
 (SEE ERIT TABLE)

**WOLVERTON**  
 Engineering Solutions You Can Trust

6745 Sugarloaf Parkway • Suite 100 • Duluth, Georgia 30097  
 Phone: 770-447-8999  
 www.wolvertoninc.com

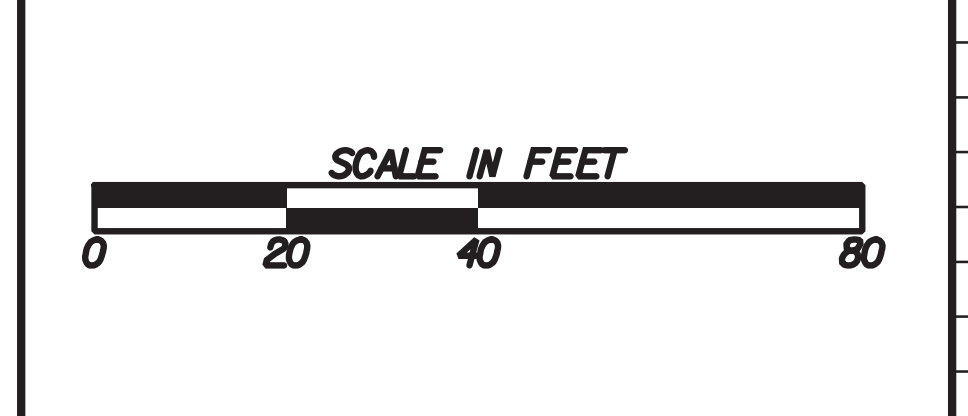

REVISION DATES	

**CITY OF DUNWOODY**

UTILITY PLANS  
 ROBERTS DRIVE

CHECKED: JKY	DATE: 01/08/19	DRAWING No. <b>24-0003</b>
BACKCHECKED: CBR	DATE: 01/10/19	
CORRECTED: LGC	DATE: 01/22/19	
VERIFIED: CBR	DATE: 01/22/19	



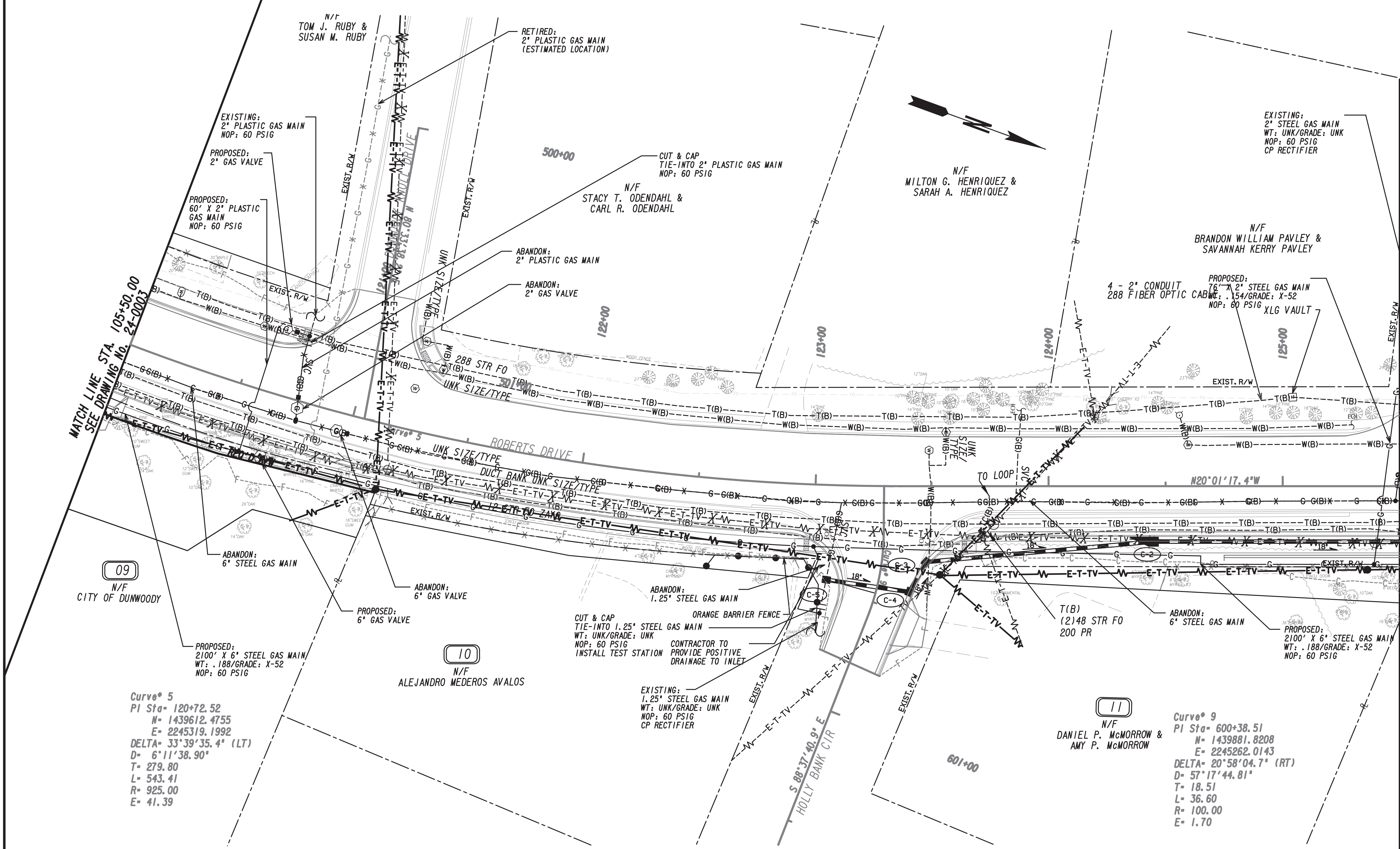
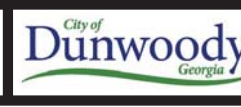

MATCH LINE STA. 105+50.00  
SEE DRAWING No. 24-0003

MATCH LINE STA. 109+50.00  
SEE DRAWING No. 24-0005

Curve\* 5  
PI Sta- 120+72.52  
N= 1439612.4755  
E= 2245319.1992  
DELTA= 33°39'35.4" (LT)  
D= 6°11'38.90"  
L= 543.41  
R= 925.00  
E= 41.39

Curve\* 9  
PI Sta- 600+38.51  
N= 1439881.8208  
E= 2245262.0143  
DELTA= 20°58'04.7" (RT)  
D= 57°17'44.81"  
L= 36.60  
R= 100.00  
E= 1.70

PROPERTY AND EXISTING R/W LINE	---
REQUIRED R/W LINE	---
CONSTRUCTION LIMITS	---
EASEMENT FOR CONSTR & MAINTENANCE OF SLOPES	---
EASEMENT FOR CONSTR OF SLOPES	---
EASEMENT FOR CONSTR OF DRIVES	---

BEGIN LIMIT OF ACCESS.....BLA	---
END LIMIT OF ACCESS.....ELA	---
LIMIT OF ACCESS	---
REQ'D R/W & LIMIT OF ACCESS	---
ORANGE BARRIER FENCE	---
ESA - ENV. SENSITIVE AREA	---
(SEE ERIT TABLE)	

**WOLVERTON**  
Engineering Solutions You Can Trust  
6745 Sugarloaf Parkway • Suite 100 • Duluth, Georgia 30097  
Phone: 770-447-8999  
www.wolvertoninc.com

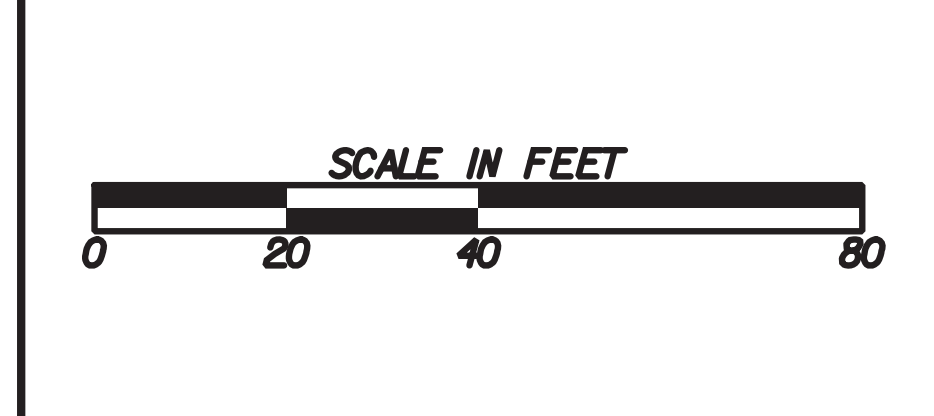

REVISION DATES	

<b>CITY OF DUNWOODY</b>			
UTILITY PLANS ROBERTS DRIVE			
CHECKED: JKY	DATE: 01/08/19	DRAWING No.	
BACKCHECKED: CBR	DATE: 01/10/19	<b>24-0004</b>	
CORRECTED: LGC	DATE: 01/22/19		
VERIFIED: CBR	DATE: 01/22/19		



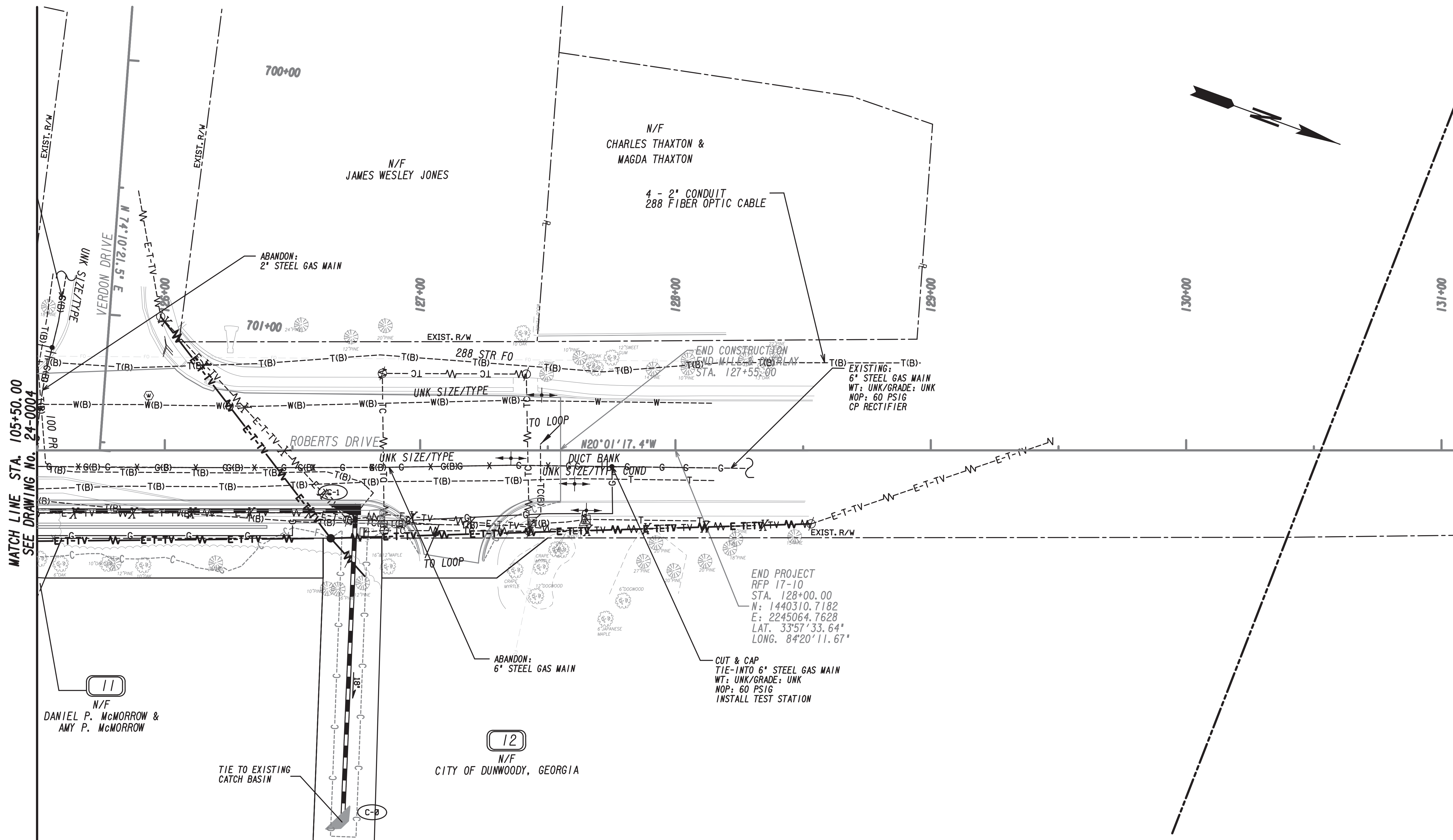
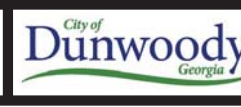

PROPERTY AND EXISTING R/W LINE  
 REQUIRED R/W LINE  
 CONSTRUCTION LIMITS  
 EASEMENT FOR CONSTR  
 & MAINTENANCE OF SLOPES  
 EASEMENT FOR CONSTR OF SLOPES  
 EASEMENT FOR CONSTR OF DRIVES

BEGIN LIMIT OF ACCESS.....BLA  
 END LIMIT OF ACCESS.....ELA  
 LIMIT OF ACCESS  
 REQ'D R/W & LIMIT OF ACCESS  
 ORANGE BARRIER FENCE  
 ESA - ENV. SENSITIVE AREA  
 (SEE ERIT TABLE)

**WOLVERTON**  
 Engineering Solutions You Can Trust  
 6745 Sugarloaf Parkway • Suite 100 • Duluth, Georgia 30097  
 Phone: 770-447-8999  
 www.wolvertoninc.com

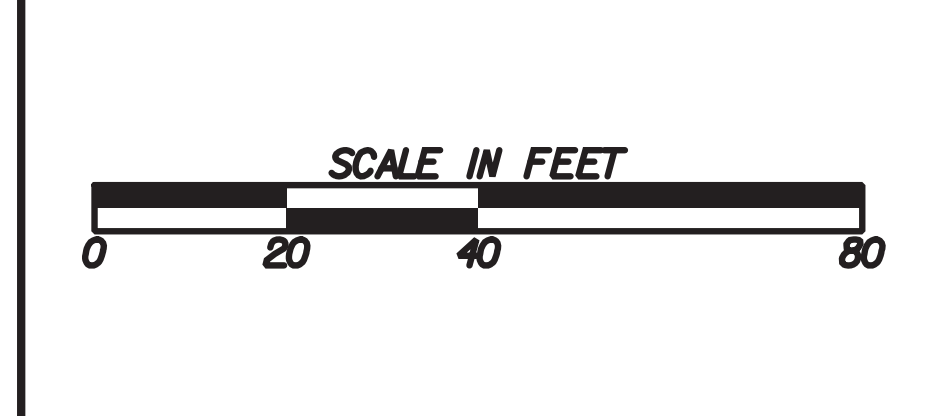

REVISION DATES	

**CITY OF DUNWOODY**  
 UTILITY PLANS  
 ROBERTS DRIVE

CHECKED: JKY	DATE: 01/08/19	DRAWING No. <b>24-0005</b>
BACKCHECKED: CBR	DATE: 01/10/19	
CORRECTED: LGC	DATE: 01/22/19	
VERIFIED: CBR	DATE: 01/22/19	

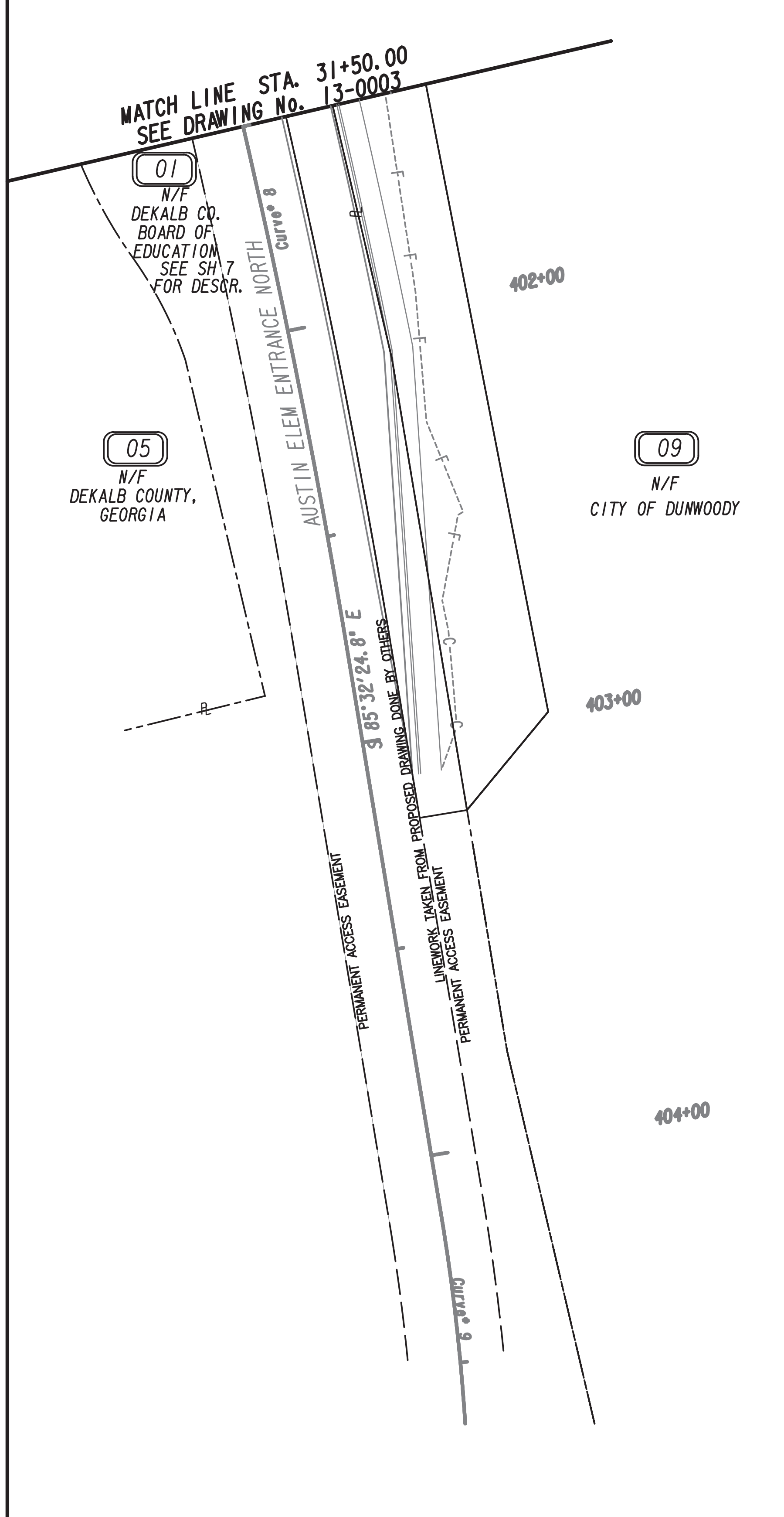
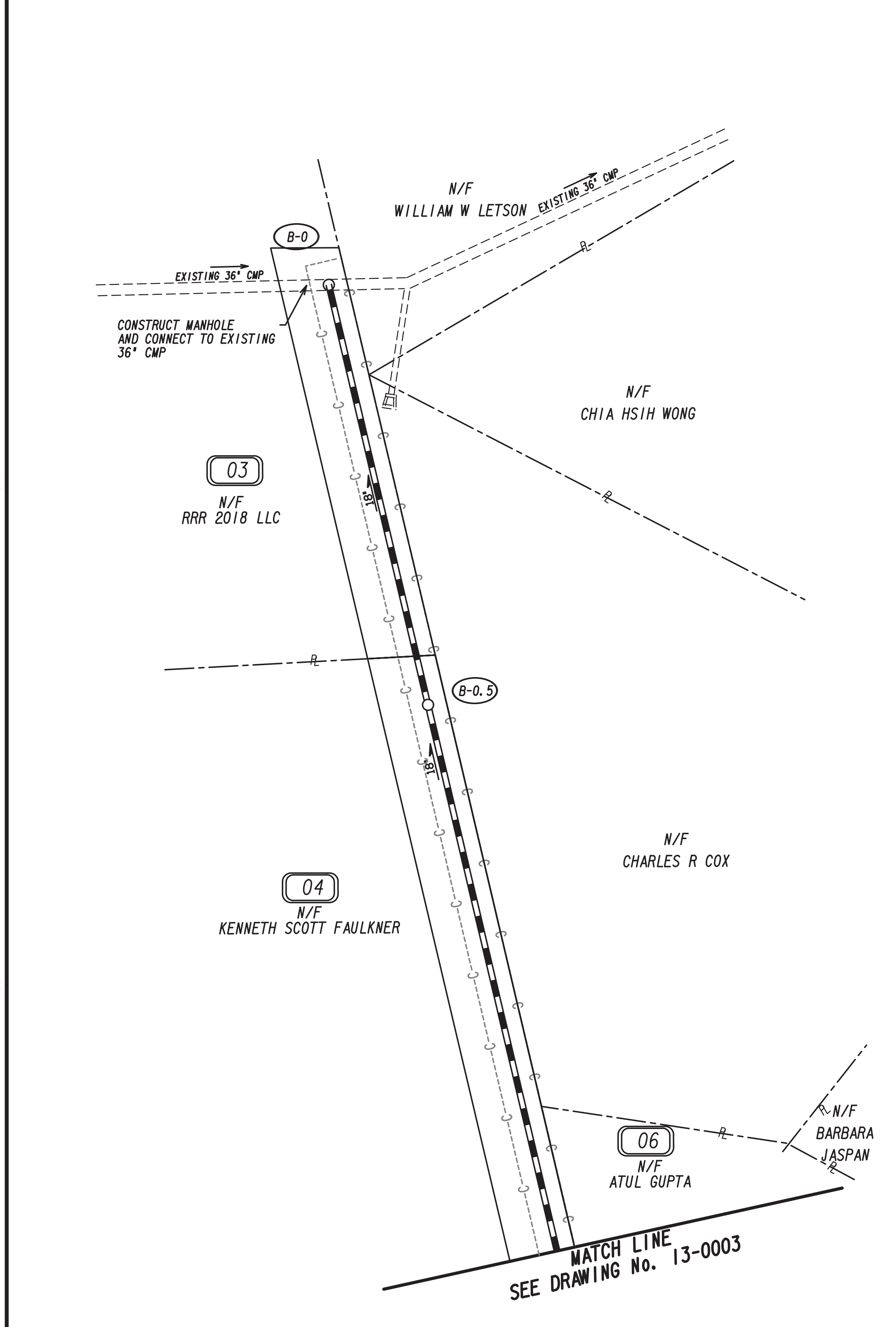
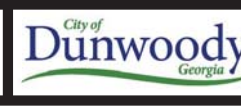

Curve 8	Curve 9
PI Sta- 402+11.51	PI Sta- 405+50.29
N- 1439452.7095	N- 1439426.3626
E- 2245485.0144	E- 2245822.8136
DELTA- 03°44'03.6" (RT)	DELTA- 30°58'10.3" (RT)
D- 02°50'41.55"	D- 11°44'27.38"
T- 65.66	T- 135.19
L- 131.27	L- 263.77
R- 2014.00	R- 488.00
E- 1.07	E- 18.38

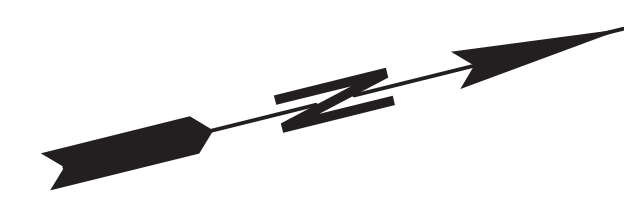

PROPERTY AND EXISTING R/W LINE	
REQUIRED R/W LINE	
CONSTRUCTION LIMITS	
EASEMENT FOR CONSTR & MAINTENANCE OF SLOPES	
EASEMENT FOR CONSTR OF SLOPES	
EASEMENT FOR CONSTR OF DRIVES	

BEGIN LIMIT OF ACCESS.....BLA	
END LIMIT OF ACCESS.....ELA	
LIMIT OF ACCESS	
REQ'D R/W & LIMIT OF ACCESS	
ORANGE BARRIER FENCE	
ESA - ENV. SENSITIVE AREA (SEE ERIT TABLE)	

**WOLVERTON**  
 Engineering Solutions You Can Trust  
 6745 Sugarloaf Parkway • Suite 100 • Duluth, Georgia 30097  
 Phone: 770-447-8999  
 www.wolvertoninc.com

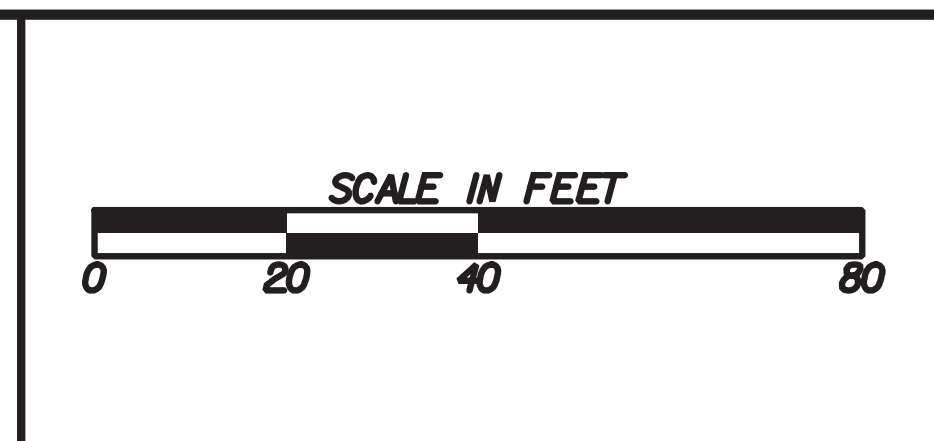

REVISION DATES	

**CITY OF DUNWOODY**  
 UTILITY PLANS  
 ROBERTS DRIVE

CHECKED: JKY	DATE: 01/08/19	DRAWING No. <b>24-0006</b>
BACKCHECKED: CBR	DATE: 01/10/19	
CORRECTED: LGC	DATE: 01/22/19	
VERIFIED: CBR	DATE: 01/22/19	







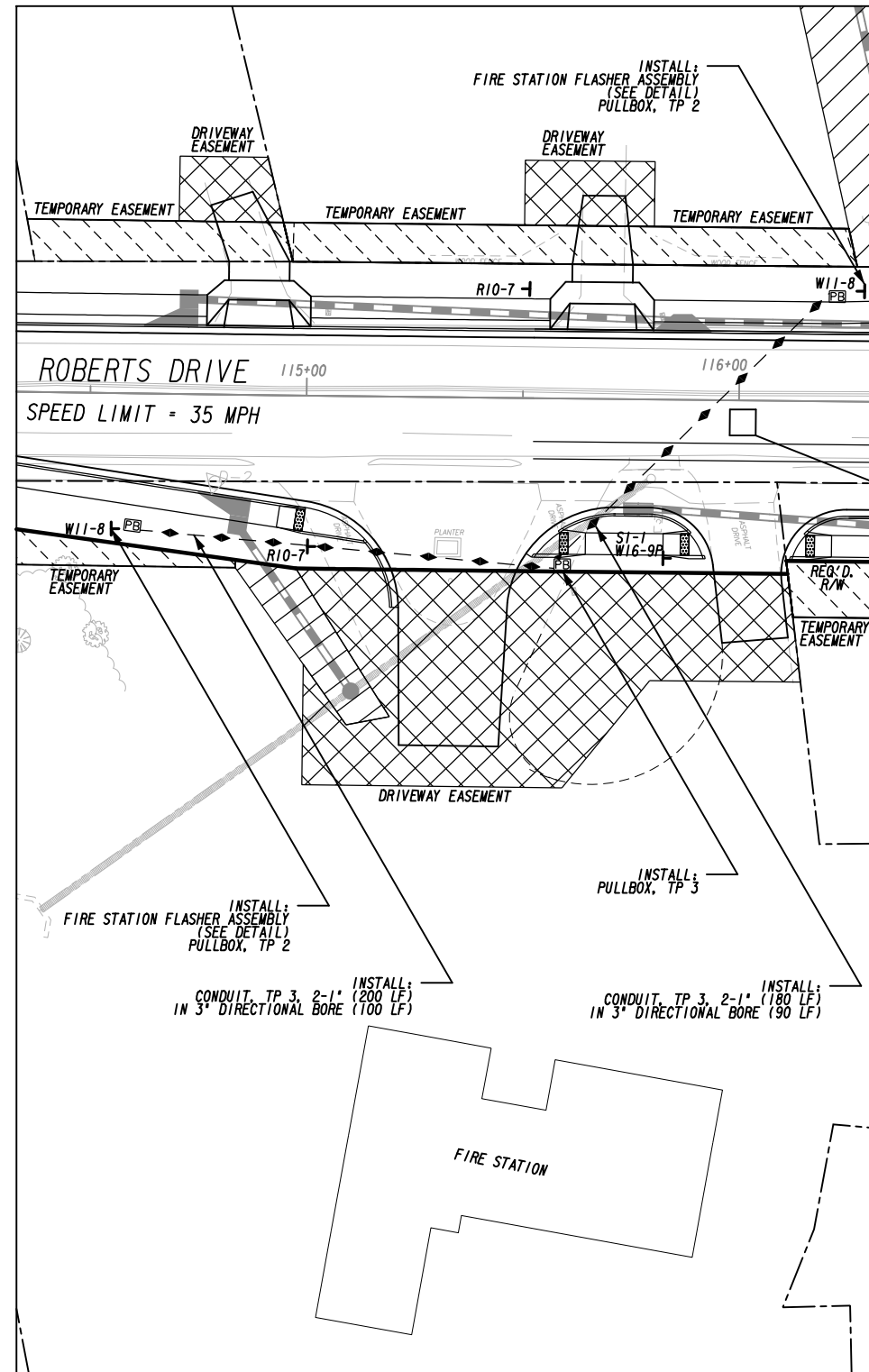

FIRE STATION FLASHER DETAIL



FIRE STATION FLASHER ASSEMBLY

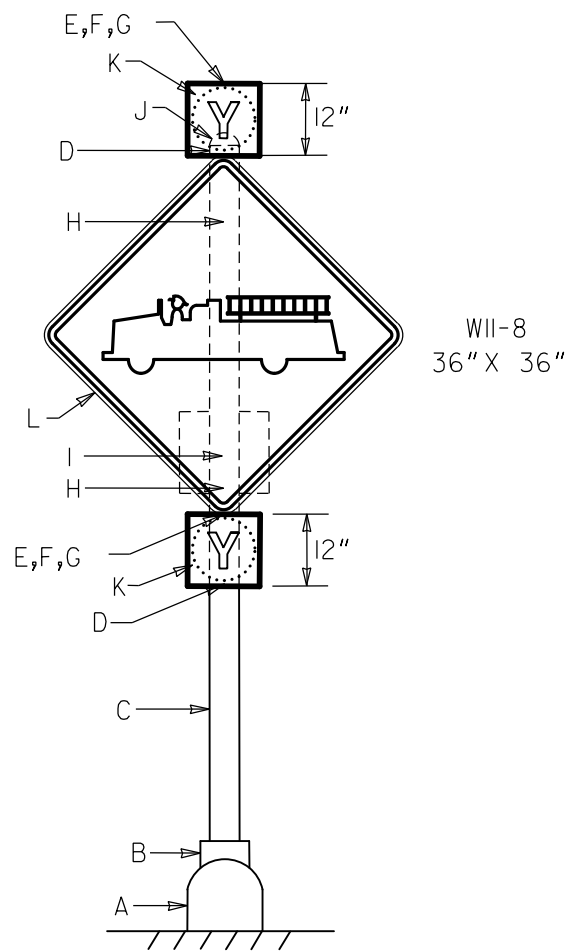

- FIRE STATION FLASHER NOTES:**
1. THE TYPE OF PROPOSED FIRE STATION FLASHER SHALL BE APPROVED BY THE CITY OF DUNWOODY PRIOR TO PURCHASING AND INSTALLATION.
  2. THE POST SUPPORTING THE FLASHER SHALL BE POWDER COATED BLACK.
  3. THE FLASHER SHALL BE EQUIPPED WITH WIRELESS ACTIVATION CAPABILITIES, SIMILAR TO THE TAPCO BLINKER BEACON OR EQUIVALENT.
  4. THE FLASHING INTERVAL SHALL BE DETERMINED BY THE CITY OF DUNWOODY.
  5. POWER FOR THE FLASHER SHALL BE ROUTED BACK TO THE TRAFFIC SIGNAL CABINET AT THE INTERSECTION OF ROBERTS DRIVE AT ROBERTS PARK ROAD. THE CITY OF DUNWOODY WILL DETERMINE THE ROUTING OF THE CABLE AND CONDUIT TO CONNECT THE FLASHER WITH THE TRAFFIC SIGNAL CABINET IN THE FIELD.

FIRE STATION FLASHER ASSEMBLY PARTS LIST

- FLASHING WARNING ASSEMBLY SHALL INCLUDE PEDESTAL POLE, FOUNDATION, GROUND ROD, SIGNAL HEADS, SIGNS AND BRACKETS.
- A. 1 EA ALUMINUM SQUARE BASE ASSY. W/ALUMINUM DOOR, PELCO PB-5335, OR EQUIV. (SHALL BE POWDER COATED BLACK)
  - B. 1 EA. POLE COLLAR ASSY., PELCO PB-5325, OR EQUIV.
  - C. 1 EA. SPUN ALUMINUM POLE, SCH 40, 13 FEET LONG, 4 1/2" O.D. X .237 WALL, PELCO PB-5100-13, OR EQUIV. (SHALL BE POWDER COATED BLACK)
  - D. 2 EA. SIGNAL BRACKET ASSY., 4" POLE SIDE MOUNT, PELCO SE-5053, OR EQUIV.
  - E. 2 EA. SIGNAL CLOSURE CAP, 1 1/2" X 2" THREADED, PELCO SE-0442, OR EQUIV.
  - F. 2 EA. NEOPRENE GASKET, PELCO SE-0354, OR EQUIV.
  - G. 2 EA. HEX NUT, 1 1/2", PELCO SE-4017, OR EQUIV.
  - H. 2 EA. U-BOLT SIGN CLAMP, PELCO SH-0206, OR EQUIV.
  - I. 1 EA. CABINET MOUNTING ASSY, 4" POLE, PELCO SE-1100 OR EQUIV.
  - J. 1 EA. POLE CAP, ALUM., ACORN TYPE, PELCO PB-5401, OR EQUIV.
  - K. 2 EA. 1-SECTION, 12" TRAFFIC SIGNAL HEAD, PLASTIC, BLACK, W/5MM PIXELATED LEDS
  - L. 1 EA. W11-8 SIGN, 36" X 36", TP 2 MATL. REFL SHEETING TP 9

**SIGNAL LEGEND**

	PROPOSED SIGNAL HEAD		PROPOSED 4-SECTION SIGNAL HEAD
	EXISTING SIGNAL HEAD		PROPOSED 5-SECTION OR 4-SECTION SIGNAL HEAD
	RELOCATED SIGNAL HEAD		PEDESTRIAN SIGNAL HEAD

**DETECTION LEGEND**

	PROPOSED INDUCTANCE LOOP		PROPOSED VIDEO DETECTION CAMERA
	PROPOSED VIRTUAL DETECTION ZONE		PROPOSED MAGNETOMETER
	PROPOSED RADAR		

**WOLVERTON**  
Engineering Solutions You Can Trust

6745 Sugarloaf Parkway • Suite 100 • Duluth, Georgia 30097  
Phone: 770-447-8999  
www.wolvertoninc.com

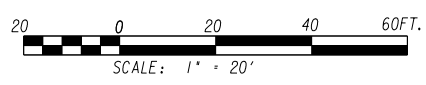

**REVISION DATES**

**SIGNAL PLANS**  
ROBERTS DRIVE @ ROBERTS PARK ROAD

CHECKED:	DATE:	DRAWING No.
BACKCHECKED:	DATE:	27-0006
CORRECTED:	DATE:	
VERIFIED:	DATE:	